



User Guide

AirLink FX Series



SIERRA
WIRELESS®

4112221
9.0
April 07, 2014

Important Notice

Due to the nature of wireless communications, transmission and reception of data can never be guaranteed. Data may be delayed, corrupted (i.e., have errors) or be totally lost. Although significant delays or losses of data are rare when wireless devices such as the Sierra Wireless modem are used in a normal manner with a well-constructed network, the Sierra Wireless modem should not be used in situations where failure to transmit or receive data could result in damage of any kind to the user or any other party, including but not limited to personal injury, death, or loss of property. Sierra Wireless accepts no responsibility for damages of any kind resulting from delays or errors in data transmitted or received using the Sierra Wireless modem, or for failure of the Sierra Wireless modem to transmit or receive such data.

Safety and Hazards

Do not operate the Sierra Wireless modem in areas where cellular modems are not advised without proper device certifications. These areas include environments where cellular radio can interfere such as explosive atmospheres, medical equipment, or any other equipment which may be susceptible to any form of radio interference. The Sierra Wireless modem can transmit signals that could interfere with this equipment. Do not operate the Sierra Wireless modem in any aircraft, whether the aircraft is on the ground or in flight. In aircraft, the Sierra Wireless modem **MUST BE POWERED OFF**. When operating, the Sierra Wireless modem can transmit signals that could interfere with various onboard systems.

Note: Some airlines may permit the use of cellular phones while the aircraft is on the ground and the door is open. Sierra Wireless modems may be used at this time.

The driver or operator of any vehicle should not operate the Sierra Wireless modem while in control of a vehicle. Doing so will detract from the driver or operator's control and operation of that vehicle. In some states and provinces, operating such communications devices while in control of a vehicle is an offence.

Limitations of Liability

This manual is provided "as is". Sierra Wireless makes no warranties of any kind, either expressed or implied, including any implied warranties of merchantability, fitness for a particular purpose, or noninfringement. The recipient of the manual shall endorse all risks arising from its use.

The information in this manual is subject to change without notice and does not represent a commitment on the part of Sierra Wireless. SIERRA WIRELESS AND ITS AFFILIATES SPECIFICALLY DISCLAIM LIABILITY FOR ANY AND ALL DIRECT, INDIRECT, SPECIAL, GENERAL, INCIDENTAL, CONSEQUENTIAL, PUNITIVE OR EXEMPLARY DAMAGES INCLUDING, BUT NOT LIMITED TO, LOSS OF PROFITS OR REVENUE OR ANTICIPATED PROFITS OR REVENUE ARISING OUT OF THE USE OR INABILITY TO USE ANY SIERRA WIRELESS PRODUCT, EVEN IF SIERRA WIRELESS AND/OR ITS AFFILIATES HAS BEEN ADVISED OF THE POSSIBILITY OF SUCH DAMAGES OR THEY ARE FORESEEABLE OR FOR CLAIMS BY ANY THIRD PARTY.

Notwithstanding the foregoing, in no event shall Sierra Wireless and/or its affiliates aggregate liability arising under or in connection with the Sierra Wireless product, regardless of the number of events, occurrences, or claims giving rise to liability, be in excess of the price paid by the purchaser for the Sierra Wireless product.

Customer understands that Sierra Wireless is not providing cellular or GPS (including A-GPS) services. These services are provided by a third party and should be purchased directly by the Customer.

SPECIFIC DISCLAIMERS OF LIABILITY: CUSTOMER RECOGNIZES AND ACKNOWLEDGES SIERRA WIRELESS IS NOT RESPONSIBLE FOR AND SHALL NOT BE HELD LIABLE FOR ANY DEFECT OR DEFICIENCY OF ANY KIND OF CELLULAR OR GPS (INCLUDING A-GPS) SERVICES.

Patents

This product may contain technology developed by or for Sierra Wireless Inc.

This product includes technology licensed from QUALCOMM®.

This product is manufactured or sold by Sierra Wireless Inc. or its affiliates under one or more patents licensed from InterDigital Group and MMP Portfolio Licensing.

Copyright

© 2014 Sierra Wireless. All rights reserved.

Trademarks

Sierra Wireless®, AirPrime®, AirLink®, AirVantage®, WISMO® and the Sierra Wireless and Open AT logos are registered trademarks of Sierra Wireless, Inc. or one of its subsidiaries.

Watcher® is a registered trademark of NETGEAR, Inc., used under license.

Windows® and Windows Vista® are registered trademarks of Microsoft Corporation.

Macintosh® and Mac OS X® are registered trademarks of Apple Inc., registered in the U.S. and other countries.

QUALCOMM® is a registered trademark of QUALCOMM Incorporated. Used under license.

Other trademarks are the property of their respective owners.

Contact Information

Sales Desk:	Phone:	1-604-232-1488
	Hours:	8:00 AM to 5:00 PM Pacific Time
	Contact:	http://www.sierrawireless.com/sales
Post:	Sierra Wireless 13811 Wireless Way Richmond, BC Canada V6V 3A4	
Technical Support:	support@sierrawireless.com	
RMA Support:	repairs@sierrawireless.com	
Fax:	1-604-231-1109	
Web:	http://www.sierrawireless.com/	

Consult our website for up-to-date product descriptions, documentation, application notes, firmware upgrades, troubleshooting tips, and press releases: www.sierrawireless.com

Document History

Version	Date	Updates
001	November 23, 2009	Creation
002	April 26, 2010	Updated Charging Specification to specify which charging method takes precedence when both options are available.
		Added section 14 Reliability Compliance and Recommended Standards .
		Removed Appendix C and moved its former contents to section 15 Certification Compliance and Recommended Standards.
		Updated Figure 5 FX100 Mechanical Drawing.
		Updated terminologies from: <ul style="list-style-type: none"> • IESM to Expansion Card • inSIM to Embedded SIM • Wireless CPU to Intelligent Embedded Module/embedded module • Open AT[®] Software Suite to <i>Sierra Wireless Software Suite</i>
		Updated 11.4 Non-Connected Mode Power Consumption
		Updated the Power Consumption values in Table 64 Initial Power Consumption (Typical).
		Added section 7.3 X-card Design Suggestion
		Updated Packaging and Product Labeling
003	October 12, 2010	Updated product pictures throughout the document
		Added a note after Figure 24 FX Series Back Interface to indicate which interfaces are available in which FX Series variant.
		Removed irrelevant AirPrime reference documents from section 17 Reference Documents
		Added information for FXT009 and FXT010 throughout the document; Removed information for FXT006, FXT007 and FXT008 throughout the document.
		Added warning information about the use of the battery accessory.
		Updated the Fastrack Supreme 20 column in Table 1.
		Updated 5.1.1.1 General Purpose Input/Output.
		Added a note for entering Sleep Mode in section 11 Power Consumption.
		Updated the Vocoder features for FXT004.
Changed instances of 6-wire power supply cable to 6-wire cable accessory.		

Version	Date	Updates
004	March 08, 2011	Updated product images throughout the document (from blue to red plate).
		Added a footnote after Table 3 FX Series Variants stating that FXT001 and FXT002 are being replaced by FXT009.
		Added information and notes specific to FXT004 throughout the document
		Updated Figure 4 FXT009 Mechanical Drawing.
		Added information about the EC0020 X-card throughout the document.
		Power Consumption tables: <ul style="list-style-type: none"> Updated Table 67 Power Consumption of FXT009 in Connected Mode with Serial Port ON and Flash LED Activated (typical values) Added FXT004 Power Consumption
		Updated Table 74 List of Recommended Accessories.
		Updated Figure 44 FX Series Product Label.
		Changed small MS to normal MS in Table 4 FX Series Basic Features.
5.0	May 03, 2012	Added 16-way IO Cable with color-coded wires shown; updated 16-way IO Expander Description.
		Updated naming conventions: "Sierra Wireless Software Suite" to "Open AT Application Framework"; "Plug-Ins" to "Libraries".
		Updated the firmware reference in the note in section 11 Power Consumption.
6.0	September 07, 2012	Updated: <ul style="list-style-type: none"> Legal boilerplates Naming conventions Section 17 Reference Documents Typo (Non-Connected mode to Connected mode) in Table 41 FX Series LED Status
6.1	December 24, 2012	Updated: <ul style="list-style-type: none"> 15.1 Certification Compliance Typo in Table 41 FX Series LED Status Reference documentation list in section 17 Reference Documents
		Added section 15.1.1 UL Listed
7.0	May 24, 2013	Added FX100 information
		Updated section 1.6.1 RoHS Directive Compliant
		Removed outdated FX Series variants
7.1	June 13, 2013	Updated: <ul style="list-style-type: none"> Table 1 FXT009 and FX100 Feature Comparison formatting 5.2.2 RF Interface 13.2 Additional Optional Accessories 19.2.6 Package
7.2	June 19, 2013	Updated Table 47 Mechanical Characteristics

Version	Date	Updates
8.0	August 28, 2013	Updated GPIO names in: <ul style="list-style-type: none">• Table 7 Power Supply Connector Pin Description• 5.1.1.1 General Purpose Input/Output• 13.1 Standard Accessories
		Updated/added Interrupt information in: <ul style="list-style-type: none">• 1.5.1 External Interfaces• 1.5.2 Internal X-card Interface• 5.1.1 Power Supply Connector• 6.6 Interrupt• Table 44 50-pin X-card Connector Description
		Updated the following figures: <ul style="list-style-type: none">• Figure 4 FXT009 Mechanical Drawing• Figure 32 Suggested X-card Dimension• Figure 37 X-card Removal Procedure
8.1	September 09, 2013	Updated typo in Table 25 Mini-B USB Pin Description
8.2	September 12, 2013	Updated 5.2.2.2 Antenna Specifications
9.0	April 07, 2014	Updated: <ul style="list-style-type: none">• 1.6.2 Disposing of the Product• Typo in section 5.2.2.2 Antenna Specifications• Section 19.2.8 Power Supply used with the FX Series



Contents

1. OVERVIEW	16
1.1. FX Series Product Comparison	16
1.2. Overall Dimensions	17
1.3. FX Series Variants and Bundles	18
1.4. Connections.....	18
1.5. Interfaces.....	18
1.5.1. External Interfaces	18
1.5.2. Internal X-card Interface.....	19
1.6. Environmental Compliance	19
1.6.1. RoHS Directive Compliant	19
1.6.2. Disposing of the Product.....	19
2. FEATURES AND SERVICES.....	20
2.1. Features and Services.....	20
2.2. Supported Bands.....	21
2.3. X-card Interface	21
2.4. Protection	22
2.4.1. Power Supply	22
2.4.2. Electrostatic Discharge	22
2.4.3. Main Serial Link.....	22
3. FUNCTIONAL SPECIFICATIONS.....	23
3.1. Functional Architecture.....	23
3.2. RF Functionalities.....	24
3.3. Operating System.....	24
4. TECHNICAL SPECIFICATIONS	25
4.1. Power Supply	25
4.2. Mechanical Specifications	26
5. INTERFACES	29
5.1. Front Interface	29
5.1.1. Power Supply Connector	29
5.1.1.1. General Purpose Input/Output	30
5.1.1.2. ON/OFF Pin.....	34
5.1.2. Serial Interface	35
5.1.2.1. RS232 Serial Link Connection	36
5.1.2.2. RS232 Implementation.....	36
5.1.2.3. Autobauding Mode	38
5.1.2.4. Serial Port Auto Shut Down Feature	38
5.1.2.5. Audio Lines Connection	39
5.1.3. USB Interface.....	42

5.2.	Back Interface.....	44
5.2.1.	SIM Interface.....	44
5.2.1.1.	SIM Socket Pin Description.....	44
5.2.2.	RF Interface	45
5.2.2.1.	RF Performances	46
5.2.2.2.	Antenna Specifications	47
5.2.2.3.	GPS Specifications for FX100.....	48
6.	SIGNALS AND INDICATORS	50
6.1.	Alarm Mode	50
6.2.	BOOT Signal Connection (FXT009 only)	50
6.3.	RESET Signal Connection	50
6.3.1.	Reset Sequence.....	51
6.4.	LED Status Indicator.....	52
6.5.	Real Time Clock (RTC)	53
6.6.	Interrupt	53
7.	X-CARD.....	54
7.1.	X-card Compartment	54
7.1.1.	Back Plate Screws	54
7.1.2.	50-pin X-card Connector	54
7.2.	X-card Physical Description	55
7.3.	X-card Design Suggestion.....	56
7.4.	FXTE02	57
7.4.1.	FXTE02 Ethernet X-card Installation	57
7.4.2.	Board Architecture	58
7.4.3.	Mechanical Characteristics	59
7.4.4.	Power Supply	59
7.4.4.1.	Extra Current Consumption from the DC-IN Source.....	59
7.5.	X-card Removal.....	60
8.	USING THE FX SERIES.....	61
8.1.	Mounting the FX Series	61
8.2.	Getting Started	62
8.2.1.	Inserting the SIM Card	64
8.2.2.	Extracting the SIM Card	65
8.3.	Using the FX Series with an X-card	66
8.4.	Operational Status.....	66
9.	COMMUNICATING WITH THE FX SERIES.....	67
9.1.	Communications Testing	67
9.2.	Verifying the Received Signal Strength.....	68
9.3.	Verifying the Network Registration	68
9.4.	Checking the Band Selection	68
9.5.	Switching Bands	69

9.6.	Checking the PIN Code Status.....	71
9.7.	Echo Function.....	71
9.8.	Enabling/Disabling the Flash LED.....	71
9.9.	Firmware Upgrade Procedure.....	71
9.10.	Main AT Commands for the FX Series.....	72
10.	TROUBLESHOOTING THE FX SERIES.....	73
10.1.	No Communications with the FX Series through the Serial Link.....	73
10.2.	Receiving “ERROR”.....	73
10.3.	Receiving “NO CARRIER”.....	74
11.	POWER CONSUMPTION.....	76
11.1.	Various Operating Modes.....	76
11.2.	Working Mode Features.....	77
11.3.	Connected Mode Power Consumption.....	78
11.4.	Non-Connected Mode Power Consumption.....	81
11.5.	Consumption Measurement Procedure.....	82
11.5.1.	Hardware Configuration.....	82
11.5.1.1.	Equipment.....	82
11.5.1.2.	SIM Cards Used.....	83
11.5.2.	Software Configuration.....	83
11.5.2.1.	FX Series Configuration.....	84
11.5.2.2.	Equipment Configuration.....	84
12.	RECOMMENDATIONS WHEN USING THE FX SERIES ON TRUCKS.....	87
12.1.	Recommended Power Supply Connection on Trucks.....	87
12.2.	Technical Constraints on Trucks.....	88
13.	FX SERIES ACCESSORIES.....	89
13.1.	Standard Accessories.....	89
13.2.	Additional Optional Accessories.....	89
13.3.	Component Recommendations.....	90
14.	RELIABILITY COMPLIANCE AND RECOMMENDED STANDARDS.....	91
14.1.	Reliability Compliance.....	91
14.2.	Applicable Standards Listing.....	91
14.3.	Environmental Specifications.....	92
14.3.1.	Function Status Classification.....	93
14.3.2.	Reliability Prediction Model.....	93
14.3.2.1.	Life Stress Test.....	93
14.3.2.2.	Environmental Resistance Stress Test.....	94
14.3.2.3.	Corrosive Resistance Stress Test.....	94
14.3.2.4.	Thermal Resistance Cycle Stress Test.....	95
14.3.2.5.	Mechanical Resistance Stress Tests.....	95
14.3.2.6.	Handling Resistance Stress Tests.....	97

15. CERTIFICATION COMPLIANCE AND RECOMMENDED STANDARDS	98
15.1. Certification Compliance.....	98
15.1.1. UL Listed	99
15.2. Applicable Standards Listing	99
16. SAFETY RECOMMENDATIONS	101
16.1. General Safety.....	101
16.2. Vehicle Safety.....	102
16.3. Care and Maintenance	102
16.4. Your Responsibility.....	102
17. REFERENCE DOCUMENTS.....	103
17.1. Firmware Documentation	103
17.2. X-card Documentation.....	103
17.3. Firmware Upgrade Documentation	103
18. LIST OF ABBREVIATIONS	104
19. PACKAGING.....	107
19.1. Contents	107
19.2. Accessories Description	107
19.2.1. GSM Antenna.....	107
19.2.2. GPS Antenna	108
19.2.3. Serial Data Cable	108
19.2.4. USB Cable.....	109
19.2.5. 6-wire Cable Accessory used with the FX Series	109
19.2.6. Package	109
19.2.7. Two Holding Bridles	109
19.2.8. Power Supply used with the FX Series.....	110
20. PRODUCT LABELING.....	111
21. SAFETY RECOMMENDATIONS (FOR INFORMATION ONLY)	112
21.1. RF Safety.....	112
21.1.1. General.....	112
21.1.2. Exposure to RF Energy.....	112
21.1.3. Efficient Terminal Operation.....	112
21.1.4. Antenna Care and Replacement.....	113
21.2. General Safety.....	113
21.2.1. Driving	113
21.2.2. Electronic Devices.....	113
21.2.3. Vehicle Electronic Equipment	113
21.2.4. Medical Electronic Equipment.....	113
21.2.5. Aircraft.....	114
21.2.6. Children	114
21.2.7. Blasting Areas	114
21.2.8. Potentially Explosive Atmospheres	114

>> | List of Figures

Figure 1.	FX Series Modem.....	17
Figure 2.	Functional Architecture.....	23
Figure 3.	FX Series RF Architecture.....	24
Figure 4.	FXT009 Mechanical Drawing	26
Figure 5.	FX100 Mechanical Drawing (1 of 2).....	27
Figure 6.	FX100 Mechanical Drawing (2 of 2).....	28
Figure 7.	FX Series Front Interface	29
Figure 8.	Power Supply Connector.....	29
Figure 9.	Equivalent Circuit of V_{IL} , $V_{ref} = 2.8V$	31
Figure 10.	Equivalent Circuit of V_{IH} , $V_{ref} = 2.8V$	31
Figure 11.	Equivalent Circuit of V_{OL} , $V_{ref} = 2.8V$	31
Figure 12.	Equivalent Circuit of V_{OH} , $V_{ref} = 2.8V$	32
Figure 13.	Equivalent Circuit of V_{IL} , $V_{ref} > 2.8V$	32
Figure 14.	Equivalent circuit of V_{IH} , $V_{ref} > 2.8V$	32
Figure 15.	Equivalent circuit of V_{OL} , $V_{ref} > 2.8V$	33
Figure 16.	Equivalent circuit of V_{OH} , $V_{ref} > 2.8V$	33
Figure 17.	15-Pin Serial Connector	35
Figure 18.	RS232 Serial Link Signals.....	36
Figure 19.	V24 Serial Link Implementation for a 5-wire UART.....	37
Figure 20.	V24 Serial Link Implementation for a 4-wire UART.....	37
Figure 21.	V24 Serial Link Implementation for a 2-wire UART.....	38
Figure 22.	Equivalent Circuit of CSPK.....	41
Figure 23.	Mini-B USB Connector	42
Figure 24.	FX Series Back Interface.....	44
Figure 25.	Main RF Connector	45
Figure 26.	Secondary RF Connector for FX100.....	45
Figure 27.	GPS RF Connector for FX100.....	45
Figure 28.	Reset Sequence Diagram	52
Figure 29.	FX Series X-card Compartment	54
Figure 30.	50-pin X-card Connector	54
Figure 31.	X-card Size.....	55
Figure 32.	Suggested X-card Dimension.....	56
Figure 33.	FXTE02 Ethernet X-card Installation on the FX Series.....	57
Figure 34.	FXTE02 Ethernet X-card Architecture.....	58
Figure 35.	FXTE02 X-card and an RJ-45 Interface Cable	58
Figure 36.	10-pin Interface Socket	58
Figure 37.	X-card Removal Procedure	60

Figure 38.	FX Series Holding Bridles	61
Figure 39.	Mounting the FX Series	61
Figure 40.	Typical Hardware Configuration for Power Consumption Measurement	83
Figure 41.	Recommended Power Supply Connection on Trucks.....	87
Figure 42.	Example of an Electrical Connection That May Damage the FX Series.....	88
Figure 43.	Holding Bridle Description	109
Figure 44.	FX Series Product Label	111

>> | List of Tables

Table 1.	FXT009 and FX100 Feature Comparison	16
Table 2.	FX Series Physical Dimensions	17
Table 3.	FX Series Variants	18
Table 4.	FX Series Basic Features.....	20
Table 5.	FX Series Variants with Corresponding Supported Bands	24
Table 6.	Power Supply Electrical Characteristics.....	25
Table 7.	Power Supply Connector Pin Description	30
Table 8.	GPIO Pin Description	30
Table 9.	GPIO Pin Operating Conditions when Vref is at 2.8V	31
Table 10.	GPIO Pin Operating Conditions when Vref > 2.8V	32
Table 11.	ON/OFF Pin Operation	34
Table 12.	ON/OFF Pin Description.....	34
Table 13.	Serial Connector Pin Description	35
Table 14.	Microphone Pin Description for FXT009	39
Table 15.	Microphone Pin Description for FX100	39
Table 16.	Equivalent Circuits of CMIC	39
Table 17.	Electrical Characteristics of CMIC for FXT009.....	39
Table 18.	Electrical Characteristics of CMIC for FX100.....	40
Table 19.	Recommended Microphone Characteristics	40
Table 20.	Speaker Outputs Pin Description for FXT009	41
Table 21.	Speaker Outputs Pin Description for FX100	41
Table 22.	Electrical Characteristics of CSPK for FXT009	41
Table 23.	Electrical Characteristics of CSPK for FX100	42
Table 24.	Recommended Speaker Characteristics.....	42
Table 25.	Mini-B USB Pin Description.....	43
Table 26.	USB Electrical Characteristics for FXT009	43
Table 27.	USB Electrical Characteristics for FX100.....	43
Table 28.	SIM Socket Pin Description.....	44
Table 29.	Available RF Interface	45
Table 30.	Main Receiver Parameters for FXT009.....	46
Table 31.	Main Transmitter Parameters for FXT009.....	46
Table 32.	Main Receiver Parameters for FX100.....	46
Table 33.	Main Transmitter Parameters for FX100.....	46
Table 34.	Antenna Specifications for FXT009 and FX100	47
Table 35.	GPS Antenna Specifications for FX100	47
Table 36.	Alarm Mode (Low Power Mode).....	50
Table 37.	FX Series Reset Status	51

Table 38.	Reset Electrical Characteristics For FXT009	51
Table 39.	Reset Electrical Characteristics for FX100.....	51
Table 40.	Reset Operating Conditions	51
Table 41.	FX Series LED Status	52
Table 42.	Real Time Clock Specifications.....	53
Table 43.	Available Interrupt Pins on the FX Series	53
Table 44.	50-pin X-card Connector Description	54
Table 45.	Basic Features of FXTE02 Ethernet X-card.....	57
Table 46.	10-pin Interface Socket Description	59
Table 47.	Mechanical Characteristics	59
Table 48.	Electrical Characteristics	59
Table 49.	Extra Current Consumption from DC-IN Source (Typical)	59
Table 50.	Basic AT Commands to Use with the FX Series.....	67
Table 51.	<rss> Value Description	68
Table 52.	AT+CREG? Main Responses	68
Table 53.	AT+WMBS? Main Responses	68
Table 54.	AT+WUBS? Main Responses.....	69
Table 55.	AT+WWSM? Main Responses	69
Table 56.	AT+WMBS Band Selection	70
Table 57.	AT+WUBS Band Selection.....	70
Table 58.	AT+WWSM Cellular Network Setting.....	70
Table 59.	AT+CPIN Main Responses	71
Table 60.	Main AT Commands used for the FX Series.....	72
Table 61.	No Communications with the FX Series Through the Serial Link	73
Table 62.	Receiving a “No Carrier” Message.....	74
Table 63.	Extended Error Codes.....	75
Table 64.	Initial Power Consumption (Typical).....	76
Table 65.	FX Series Operating Modes.....	76
Table 66.	FX Series Operating Modes Feature Availability	77
Table 67.	Power Consumption of FXT009 in Connected Mode with Serial Port ON and Flash LED Activated (typical values)	78
Table 68.	Power Consumption of FX100 in Connected Mode with Serial Port OFF, Flash LED OFF and USB ON (typical values)	79
Table 69.	Power Consumption of FXT009 in Non-Connected Mode (typical values).....	81
Table 70.	Power Consumption of FX100 in Non-Connected Mode with UART ON, FLASH LED OFF and USB OFF (typical values)	82
Table 71.	List of Recommended Equipments	83
Table 72.	Operating Mode Information.....	84
Table 73.	6-Wire Cable Accessory Color Coding.....	89
Table 74.	List of Recommended Accessories.....	90
Table 75.	Standards Conformity for the FX Series	91

Table 76.	Applicable Standards and Requirements for the FX Series.....	91
Table 77.	Operating Class Temperature Range	92
Table 78.	ISO Failure Mode Severity Classification	93
Table 79.	Life Stress Test.....	93
Table 80.	Environmental Resistance Stress Test	94
Table 81.	Corrosive Resistance Stress Test.....	94
Table 82.	Thermal Resistance Cycle Stress Test	95
Table 83.	Mechanical Resistance Stress Tests	95
Table 84.	Handling Resistance Stress Tests	97
Table 85.	Standards Conformity for FXT009.....	98
Table 86.	Standards Conformity for FX100.....	98
Table 87.	Applicable Standards and Requirements for FXT009.....	99
Table 88.	Applicable Standards and Requirements for FX100	100
Table 89.	Configuration Availability for the FX Series	107
Table 90.	GSM Antenna Description.....	107
Table 91.	GPS Antenna Description	108
Table 92.	Serial Data Cable Description	108
Table 93.	6-wire Cable Accessory Description.....	109
Table 94.	Packaging Description.....	109
Table 95.	Power Supply Description	110
Table 96.	Power Supply Temperature Range for Ready to Use Bundles.....	110

>> 1. Overview

The AirLink FX Series is a line of industrial grade USB and serial programmable modems supporting penta-band 3G HSPA+ with dual antenna receive diversity and/or quad band 2G GSM/GPRS/EGDE. It offers audio capabilities, GPS and digital I/O interfaces; and Ethernet connectivity as an option. It also offers an Expansion card (X-card) interface accessible for customer use.

The FX Series supports the AirVantage M2M Cloud Management Services and Enterprise Platform; and also supports the Open AT Application Framework. The Open AT Application Framework is a complete software package for developing embedded M2M applications in standard C/C++.

This document does not cover the programmable capabilities available through the Open AT Application Framework or the management capabilities available through the AirVantage M2M Cloud. For more information about the Open AT Application Framework or the AirVantage M2M Cloud Management Services and Enterprise Platform, please visit <http://developer.sierrawireless.com/>.

1.1. FX Series Product Comparison

The following table lists the main feature differences between the two FX series variants.

Table 1. FXT009 and FX100 Feature Comparison

Feature		FXT009	FX100
GSM	900 MHz	✓	✓
	1800 MHz	✓	✓
	850 MHz	✓	✓
	1900 MHz	✓	✓
HSPA	800 MHz	-	✓
	850 MHz	-	✓
	900 MHz	-	✓
	1900 MHz	-	✓
	2100 MHz	-	✓
GPRS	Class 10	✓	✓
	Class 12	-	✓
EDGE	Class 10	✓	✓
	Class 12	-	✓
Voice		✓	✓
Vocoder	HR	✓	✓
	FR	✓	✓
	EFR	✓	✓
	AMR	✓	✓
Data		✓	✓
Fax		✓	-
SIM Interface (1.8/3V)		✓	✓
Serial Port Auto Shut Down		✓	✓
RTC Back Up Battery		✓	✓
X-card Flexibility		✓	✓
Open AT Application Framework Compliant		✓	✓

Feature	FXT009	FX100
gpsOneXTRA™	-	✓
Embedded GPS	-	✓
Primary RF Interface	✓	✓
Secondary RF Interface	-	✓
GPS MMCX Connector Interface	-	✓
USB Interface	✓	✓
10-pin Micro-Fit Connector Interface	✓	✓
15-pin sub-D Serial Interface	✓	✓

For more information on the features available on the FX Series variants, refer to Table 4 FX Series Basic Features.

1.2. Overall Dimensions



Figure 1. FX Series Modem

Table 2. FX Series Physical Dimensions

Length	89 mm
Width	60 mm
Thickness	30 mm
Weight	100g for FXT009 125g for FX100

1.3. FX Series Variants and Bundles

Table 3. FX Series Variants

Product	Bundle	Description
FXT009	Standard	Wireless connectivity: EGSM Quad Band + CL 10 GPRS + EDGE Wired connectivity: Serial, USB Accessories: DC Cable, USB cable, Holding Bridles
	Ready to Use	Wireless connectivity: EGSM Quad Band + CL 10 GPRS + EDGE Wired connectivity: Serial, USB Accessories: DC Cable, USB cable, Holding Bridles, Cellular Antenna, Power Supply, Data Cable
	Ready to Use Ethernet	Wireless connectivity: EGSM Quad Band + CL 10 GPRS + EDGE Wired connectivity: Serial, USB, Ethernet Accessories: DC Cable, USB cable, Holding Bridles, Cellular Antenna, Power Supply, Data Cable, FXTE02 Ethernet X-card, Ethernet RJ45 dongle
FX100	Standard	Wireless connectivity: EGSM Quad Band + CL 12 GPRS + EDGE + HSxPA + Penta Band HSPA+ Wired connectivity: Serial, USB Accessories: DC Cable, Holding Bridles
	Ready to Use	Wireless connectivity: EGSM Quad Band + CL 12 GPRS + EDGE + HSxPA + Penta Band HSPA+ Wired connectivity: Serial, USB Accessories: DC Cable, USB cable, Holding Bridles, Cellular Antenna, Diversity Antenna, GPS Antenna, Power Supply, Data Cable

Note: Available wireless interfaces will vary depending on the FX Series variant. Refer to Table 4 FX Series Basic Features for more details on the basic features available on each variant.

1.4. Connections

- 10-pin Micro-Fit Power Supply Connector
- USB Interface
- 15-pin Sub-D Serial Interface
- SIM Interface
- Antenna Interface
 - SMA Main
 - SMA Diversity (3G-HSxPA version) for FX100
 - GPS for FX100

1.5. Interfaces

1.5.1. External Interfaces

- Power Supply
- 3V/1V8 SIM Interface
- USB (slave) Interface
- Serial Link (UART1)

- ON/OFF
- Boot (for FXT009 only)
- 1 Interrupt (multiplexed in the Microfit connector)
- Reset
- Audio Interface
- 2 GPIOs
- LED Status Indicator

1.5.2. Internal X-card Interface

- 1 Secondary Serial Link (UART2)
- 6 GPIOs
- 2 SPI Bus
- 1 ADC
- 1 DAC (except for FX100)
- 1 PCM
- 1 Interrupt for FX100; 2 Interrupts for FXT009
- Reset access to the embedded module
- Boot access to the embedded module (except for FX100)
- 2.8V supply from the FX Series
- 4V supply from the FX Series
- 2.8V Digital supply from the embedded module
- 1.8V Digital supply from the embedded module
- Access to 4.75 to 32V DC-IN

1.6. Environmental Compliance

1.6.1. RoHS Directive Compliant

The FX Series is compliant with RoHS Directive 2011/65/EU which sets limits for the use of certain restricted hazardous substances. This directive states that “from 1st July 2006, new electrical and electronic equipment put on the market does not contain lead, mercury, cadmium, hexavalent chromium, polybrominated biphenyls (PBB) or polybrominated diphenyl ethers (PBDE)”.

1.6.2. Disposing of the Product

This electronic product is subject to the EU Directive 2012/19/EU for Waste Electrical and Electronic Equipment (WEEE). As such, this product must not be disposed of at a municipal waste collection point. Please refer to local regulations for directions on how to dispose of this product in an environmental friendly manner.



2. Features and Services

This section enumerates the features and services available on the FX Series.

2.1. Features and Services

Refer to the table below for the list of basic features available on the FX Series.

Table 4. FX Series Basic Features

Features	Description
Open AT Application Framework	<ul style="list-style-type: none"> • Open AT Application Framework programmable: <ul style="list-style-type: none"> ▪ Native execution of embedded standard ANSI C applications ▪ Custom AT command creation ▪ Custom application library creation ▪ Standalone operation • Interface for embedded applications • Library compatible
Standard	<ul style="list-style-type: none"> • 850MHz / 900 MHz • E-GSM compliant • Output power: class 4 (2W) • Fully compliant with ETSI GSM phase 2 + normal MS <ul style="list-style-type: none"> • 1800 MHz / 1900MHz • Output power: class 1 (1W) • Fully compliant with ETSI GSM phase 2 + normal MS
GPRS	<ul style="list-style-type: none"> • Class 10 • Class 12 (FX100 only) • PBCCH support • Coding schemes: CS1 to CS4 • Compliant with SMG31bis • Embedded TCP/IP stack
EGPRS	<ul style="list-style-type: none"> • Class 10 • Class 12 (FX100 only) • PBCCH support • Coding schemes: MCS1 to MCS9 • Compliant with SMG31bis • Embedded TCP/IP stack
Interface	<ul style="list-style-type: none"> • RS232 (V.24/V.28) Serial interface supporting: <ul style="list-style-type: none"> ▪ Baud rate (bits/s): 300, 600, 1200, 2400, 4800, 9600, 19200, 38400, 57600, 115200, 230400, 460800 and 921600 ▪ Autobauding (bits/s): from 1200 to 921600 ▪ 2 General Purpose Input/Output gates (GPIOs) available • 1.8 V / 3 V SIM interface • AT command set based on V.25ter and GSM 07.05 & 07.07
SMS	<ul style="list-style-type: none"> • Text & PDU • POINT TO POINT (MT/MO) • Cell broadcast

Features	Description
Data	<ul style="list-style-type: none"> • Data circuit asynchronous • Transparent and Non Transparent modes • Up to 14.400 bits/s • MNP Class 2 error correction • V42.bis data compression
UMTS Data Transfer (FX100 only)	BAND I, II, V, VI, VIII (2100/1900/850/800/900) up to 384kbits/s
HSXPA (FX100 only)	<ul style="list-style-type: none"> • BAND I, II, V, VI, VIII (2100/1900/850/800/900) • HSDPA Cat 10 up to 14.4Mbits/s • HSUPA Cat 6 up to 5.76Mbits/s
FAX (FXT009 only)	Automatic fax group 3 (class 1 and class 2)
Audio	<ul style="list-style-type: none"> • Echo cancellation • Noise reduction • Full Rate, Enhanced Full Rate, Half Rate operation and Adaptive Multi-Rate (FR/EFR/HR/AMR) • Dual Tone Multi Frequency function (DTMF). Note that this can be supported by FX100 with Firmware 7.52.A1 or later.

2.2. Supported Bands

The FX Series come in two variants, supporting various bearers and bands. The FXT009 is a quad band programmable modem that support either EU bands (EGSM900/DCS1800) or US bands (GSM850/PCS1900). Users may switch from one supported band to another by using AT commands.

The FX100 is also a quad band EGSM900/DCS1800/GSM850/PCS1900 that also supports penta band UMTS/HSPA (WCDMA-FDD) 2100/1900/850/800/900 (Band I, II, V, VI and VIII). Band selection is done automatically without having to switch manually using AT commands.

Refer to sections 9.4 Checking the Band Selection and 9.5 Switching Bands for more information regarding switching bands.

2.3. X-card Interface

The FX Series offers a 50-pin X-card interface accessible to customers. It is an additional interface for customers to expand their application features by simply plugging in an X-card through the mating connector of the X-card interface.

Refer to section 7 X-card for more information about the X-card supported by the FX Series.

2.4. Protection

2.4.1. Power Supply

The FX Series is protected from continuous over-voltage by a 2A/250V slow break fuse directly bonded on the 6-wire cable accessory; and it is also protected against transient voltage peaks over +32V. When the input voltage exceeds 32V, the supply voltage is automatically disconnected in order to protect the internal electronic components from overvoltage.

2.4.2. Electrostatic Discharge

The FX Series withstands ESD according to IEC 1000-4-2 requirements for all accessible parts, except for the RF connector which withstands ESD as follows:

- +/- 8kV of air discharge
- +/- 4kV of contact discharge

2.4.3. Main Serial Link

The FX Series' RS232 serial link connection is internally protected against electrostatic surges on its lines by ESD protection and it also has the following filtering guarantees:

- EMI/RFI protection on both input and output
- Signal smoothing

3. Functional Specifications

This section discusses the functional specifications of the FX Series.

3.1. Functional Architecture

The global architecture of the FX Series is shown in the figure below.

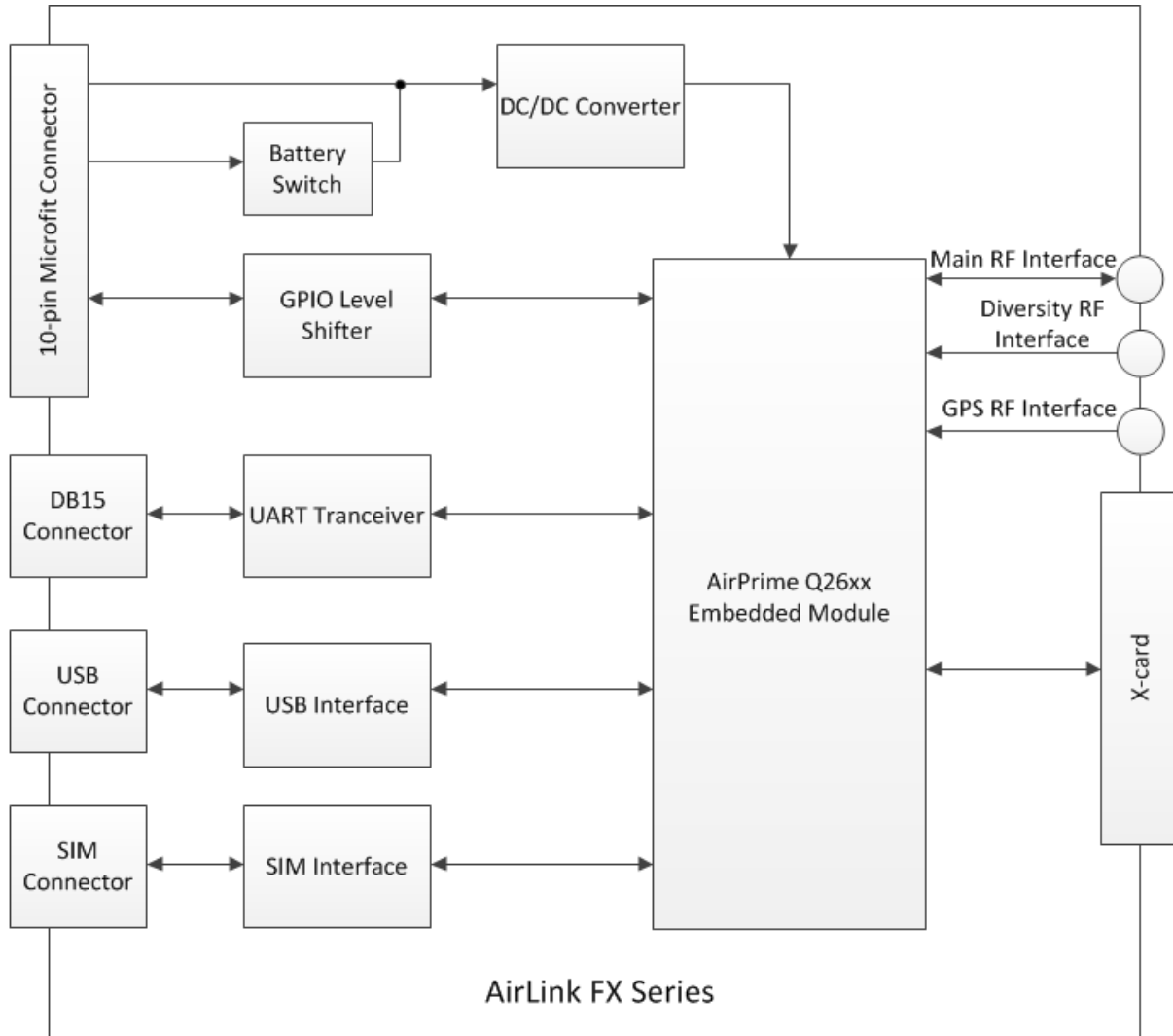

Note: Diversity and GPS RF Interfaces are only available on FX100.

Figure 2. Functional Architecture

3.2. RF Functionalities

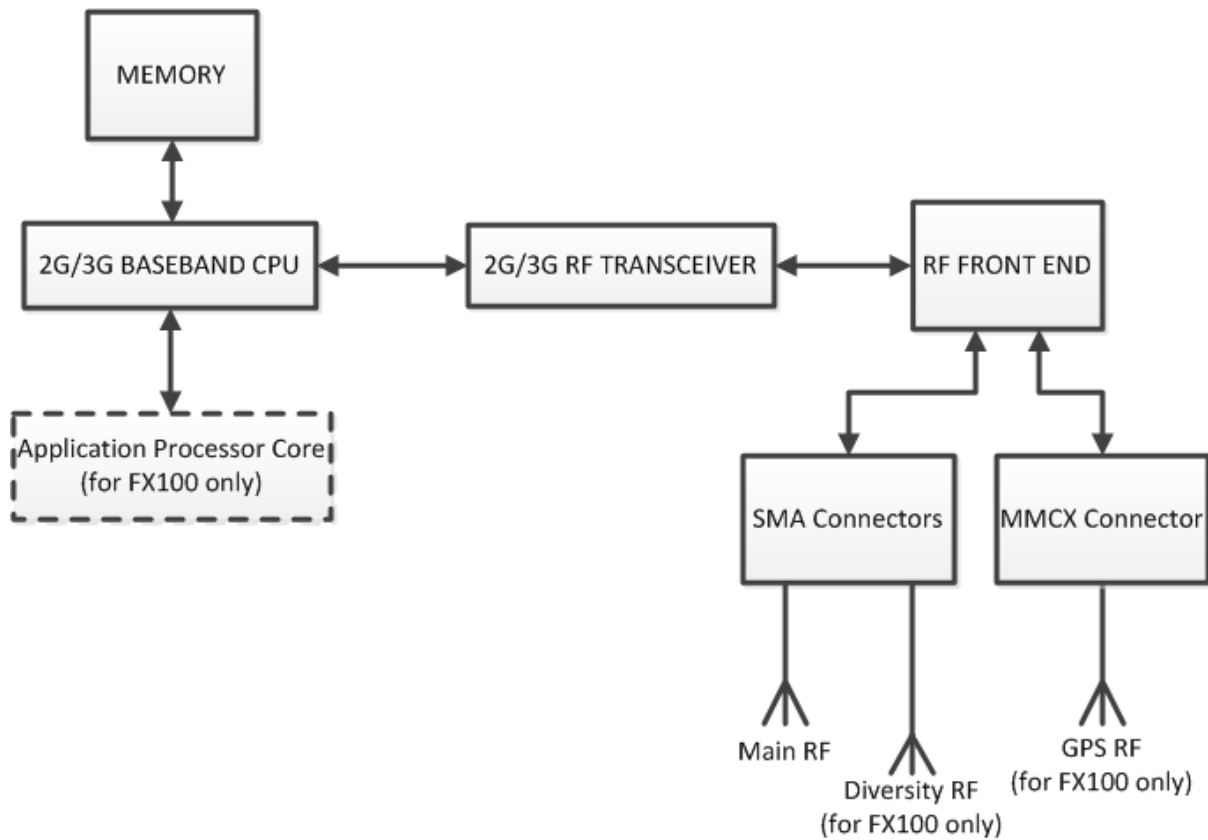

Figure 3. FX Series RF Architecture

Refer to the table below for the list of FX Series variants and their corresponding supported bands.

Table 5. FX Series Variants with Corresponding Supported Bands

FX Series Variant	Supported Bands
FXT009	Quad band (850/900/1800/1900 MHz)
FX100	Quad band (850/900/1800/1900 MHz) Penta band UMTS/HSPA (800/850/900/1900/2100 MHz)

3.3. Operating System

The FX Series is Open AT Application Framework compliant. With the Open AT Application Framework, customers can embed their own applications with the FX Series and turn the FX Series into a solution for their specific market need. The operating system of the FX Series is also responsible for the following functions:

- AT Command processing
- Real Time Clock (RTC) with calendar

>> 4. Technical Specifications

4.1. Power Supply

The FX Series is supplied by an external DC voltage, DC-IN, with a voltage range of +4.75V to +32V.

The main regulation is made with an internal DC/DC converter in order to supply all the internal functions with a DC voltage. The correct operation of the FX Series in Communication mode is not guaranteed if the input voltage falls below 4.75V.

Refer to the following table for the FX Series' operating voltage range and maximum current.

Table 6. Power Supply Electrical Characteristics

Operating Voltage Range	4.75V to 32V DC, nominal at 13.2V
Maximum Current (Typical)	<ul style="list-style-type: none">• 600mA, average at 4.75V; 3A Peak at 4.75V on FXT009• 850mA, average at 4.75V; 3.7A Peak at 4.75V on FX100

The FX Series is permanently powered once the power supply is connected. In the case of Alarm mode (Low Power mode), the user can set the FX Series "Turn-on" time. Refer to section 6.1 Alarm Mode for more information.

Caution: *The minimum input voltage specified here is the FX Series input. Be mindful of the input voltage decrease caused by the power cable. When using the 6-wire cable accessory that comes with the FX Series package, this input drop is at around 800mV at 4.75V and 220mV at 32V (EDGE 4TX).*

*The FX Series is designed for use with the original power cable, and the fuse that came with the original cable is a 2A/250V Slow Break fuse 5.2mm*20mm.*

4.2. Mechanical Specifications

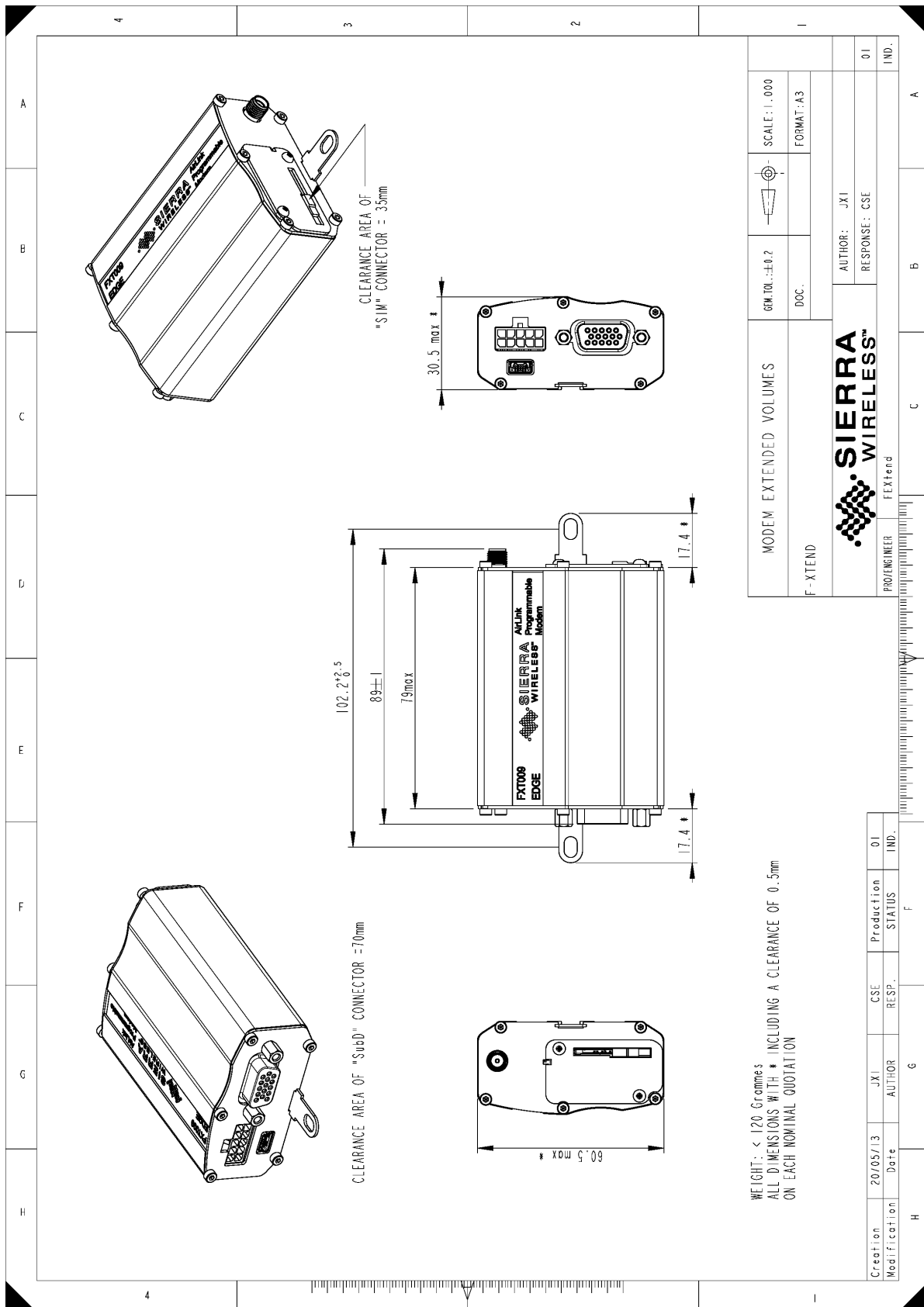

Figure 4. FXT009 Mechanical Drawing

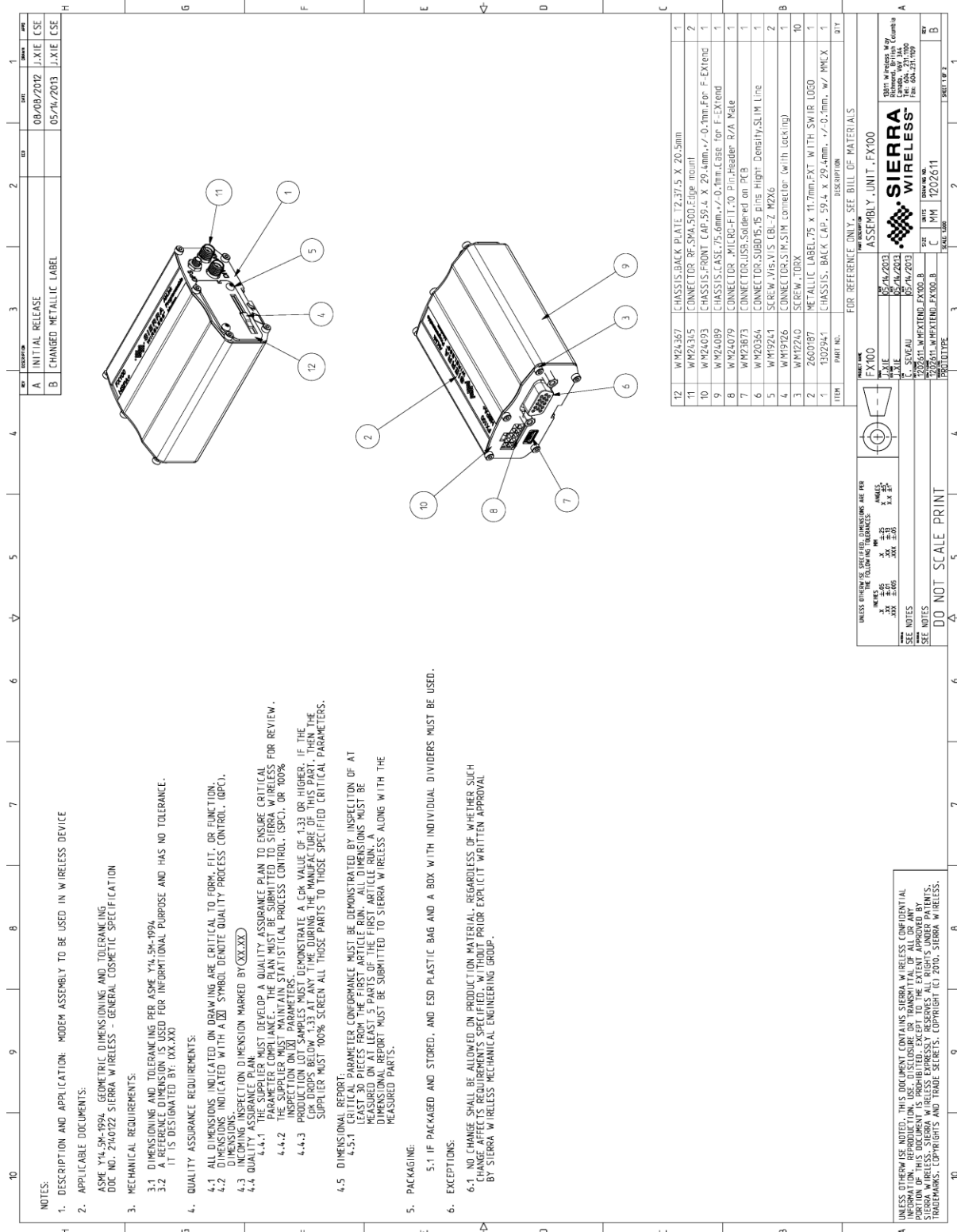

Figure 5. FX100 Mechanical Drawing (1 of 2)

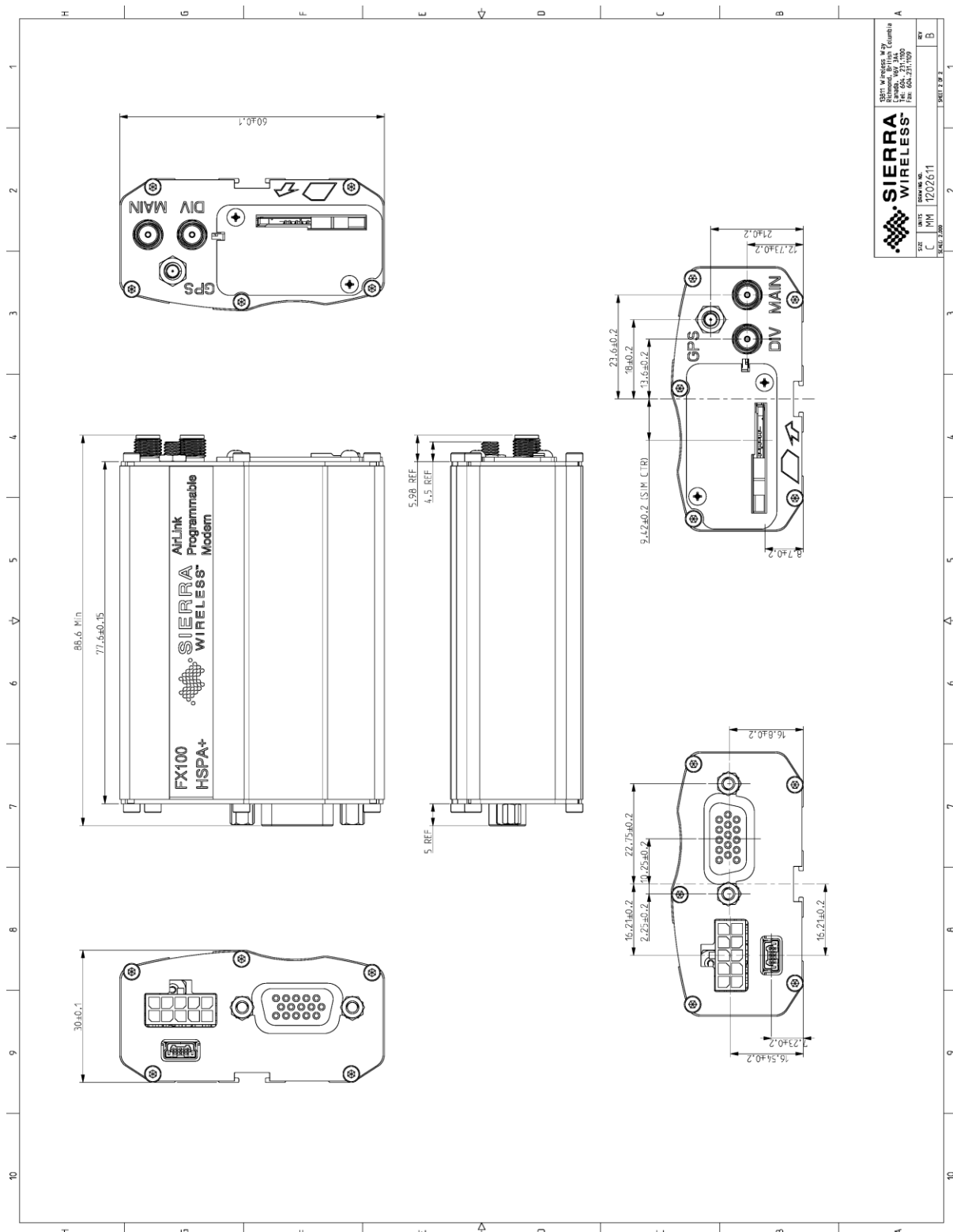

Figure 6. FX100 Mechanical Drawing (2 of 2)

>> 5. Interfaces

This section describes the different interfaces that connect with the FX Series. The FX Series comes with the following interfaces:

- 10-pin Micro-Fit Connector
- USB Interface (mini-B connector)
- 15-pin Sub-D Serial Interface
- Main RF Interface
- Secondary RF Interface (for FX100 only)
- GPS RF Interface (for FX100 only)
- SIM Interface
- LED Status Indicator

5.1. Front Interface

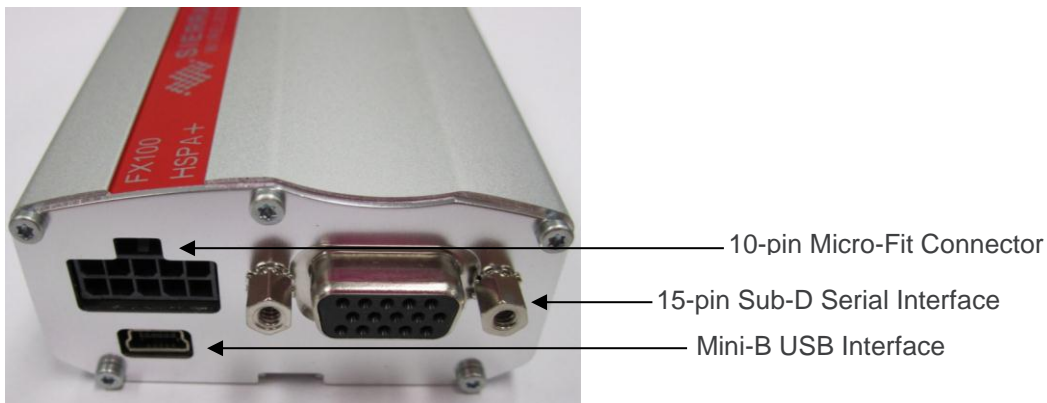

Figure 7. FX Series Front Interface

5.1.1. Power Supply Connector

The power supply connector is a 10-pin Micro-Fit connector that is used for:

- External DC Power Supply connection with voltage from +4.75V to +32V, at 3A on FXT009 and 3.7A on FX100
- GPIOs connection and GPIO voltage reference
- ON/OFF pin to power OFF the FX Series
- Interrupt pin

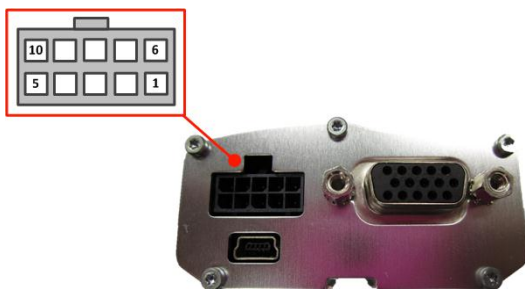

Figure 8. Power Supply Connector

Refer to the following table for the pin description of the power supply connector.

Table 7. Power Supply Connector Pin Description

Pin #	Signal	Description
1	GPIO25/INT1	General purpose input/output or Interrupt
2	GPIO21 for FXT009; GPIO35 for FX100	General purpose input/output
3	Vref	Voltage reference for the GPIOs
4	Reserved	Reserved
5	Reserved	Reserved
6	GND	Ground
7	DC-IN	Input Supply for the FX Series (4.75V to 32V)
8	ON/OFF	Control pin to power OFF the FX Series
9	Reserved	Reserved
10	Reserved	Reserved

The input voltage range (DC-IN) is from 4.75V to 32V, with a typical operating voltage of 13.2V.

The power cable is provided as part of the FX Series package.

Caution: Pins 1, 2, 3, 4, 5, 8, 9 and 10 are low voltage interfaces. It is strictly prohibited to connect these pins to any power supply as there is a risk of damaging the FX Series.

5.1.1.1. General Purpose Input/Output

The FX Series has two external GPIO ports:

- GPIO21 for FXT009, GPIO35 for FX100
and
- GPIO25;

as well as a voltage reference line, **Vref**.

Vref sets the reference voltage of the input or output of the two GPIOs. Leaving it unconnected sets the GPIO level at 2.3V – 2.6V by default. It is **strongly** recommended to connect to the required GPIOs' output voltage (2.8V ~ 15V).

Refer to the following table for the pin description of the GPIOs.

Table 8. GPIO Pin Description

Pin #	Signal	I/O	I/O Voltage	Description
1	GPIO25/INT 1	I/O	Vref	General purpose input/output or Interrupt
2	GPIO21 for FXT009; GPIO35 for FX100	I/O	Vref	General purpose input/output
3	Vref	I	2.8V ~ 15V	Voltage reference for the GPIOs

Note: It is recommended to use a **6-wire cable accessory** for easy access to these three lines. Please refer to section 13.1 Standard Accessories for more information about the 6-wire cable accessory.

When the voltage reference, **Vref**, is not connected, if one of the GPIO output is in High state while the other is in Low state, the GPIO in high level voltage will be at 2.3V. To avoid this voltage drop, it is recommended to use **Vref** to the desired output voltage.

With **Vref** connected to 2.8V, both GPIO21 (GPIO35 for FX100) and GPIO25 may be interfaced with a component that complies with the following levels.

Table 9. GPIO Pin Operating Conditions when Vref is at 2.8V

Parameter	Minimum	Typical	Maximum	Condition
V _{IL}			0.84V	Please refer to Figure 9.
V _{IH}	1.96V			Please refer to Figure 10.
V _{OL}			0.4*	Please refer to Figure 11.
V _{OH}	2.8*			FX Series Zout = 100K Pull-up to Vref , please refer to Figure 12.

* Value without external load.

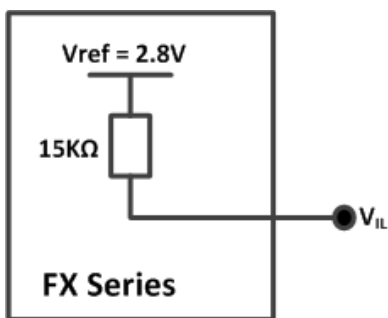

Figure 9. Equivalent Circuit of V_{IL}, Vref = 2.8V

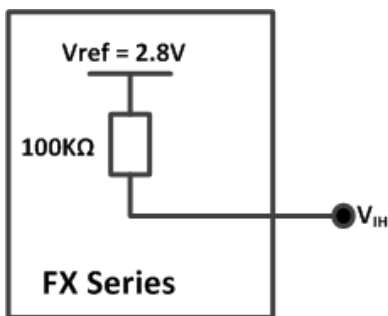

Figure 10. Equivalent Circuit of V_{IH}, Vref = 2.8V

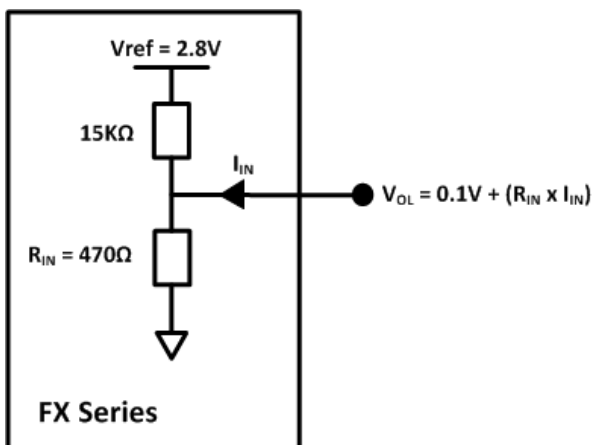

Figure 11. Equivalent Circuit of V_{OL}, Vref = 2.8V

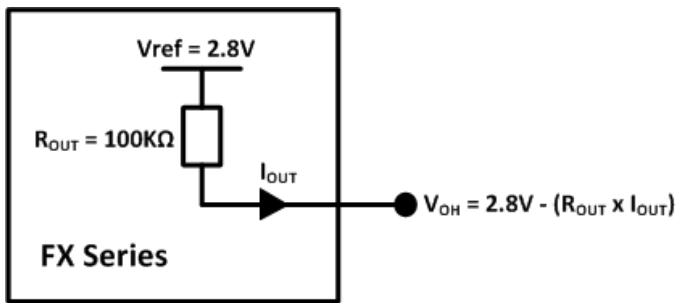

Figure 12. Equivalent Circuit of V_{OH} , $V_{ref} = 2.8V$

With $V_{ref} > 2.8V$, both GPIO21 (GPIO35 for FX100) and GPIO25 may be interfaced with a component that complies with the following levels.

Table 10. GPIO Pin Operating Conditions when $V_{ref} > 2.8V$

Parameter	Min	Typ	Max	Condition
V_{IL}			0.84V	Please refer to Figure 13.
V_{IH}	1.96V			Please refer to Figure 14.
V_{OL}			$\frac{V_{ref}}{110} + 0.058^*$	Please refer to Figure 15.
V_{OH}	V_{ref}^*			FX Series $Z_{out} = 100K$ Pull-up to V_{ref} , please refer to Figure 16.

* Value without external load.

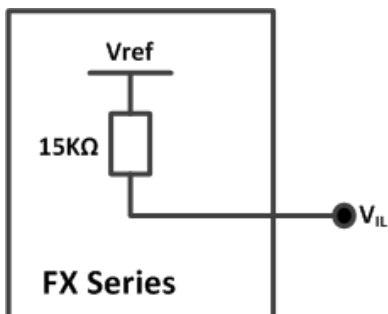

Figure 13. Equivalent Circuit of V_{IL} , $V_{ref} > 2.8V$

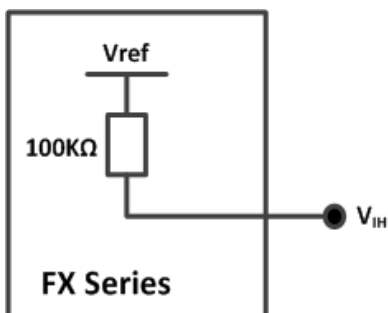

Figure 14. Equivalent circuit of V_{IH} , $V_{ref} > 2.8V$

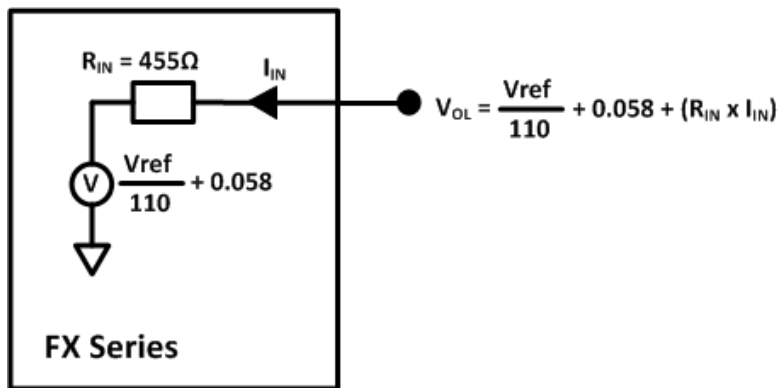

Figure 15. Equivalent circuit of V_{OL} , $V_{ref} > 2.8V$

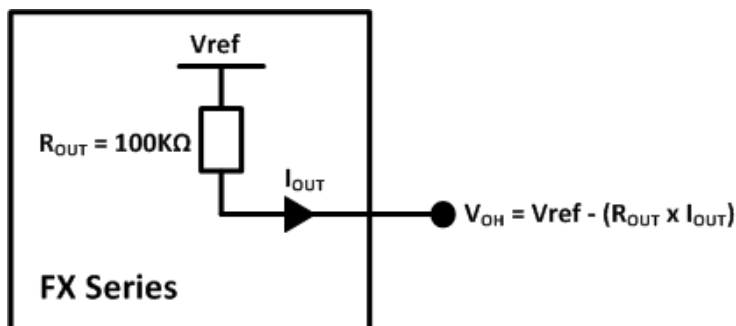

Figure 16. Equivalent circuit of V_{OH} , $V_{ref} > 2.8V$

The GPIO pin is mainly used to:

- Act as a switch for a transistor when the GPIO is configured as output.
- Act as a status reading when the GPIO is configured as input.

The GPIOs may be controlled with the following AT commands:

- **AT+WIOW** for write access to the GPIO value, when the GPIO is used as an output
- **AT+WIOR** for read access to the GPIO value, when the GPIO is used as an input

By default, and when the FX Series has been reset, both GPIOs are configured as inputs. The AT command **AT+WIOM** must be used to change this configuration. Refer to documents [1] Open AT Application Framework AT Commands Interface Guide and [2] AirPrime SL808xT and Q2698 Open AT Framework Commands Interface Guide for more information regarding this AT command.

5.1.1.1.1. Setting the GPIO as an Output

Refer to the following example for how to configure the GPIO as an output.

- Enter the following commands:
 - **AT+WIOM=1,"GPIO21",1,0** → this command activates GPIO21 as an output and sets it at a low level.
 - **AT+WIOW="GPIO21",1** → this command sets the output level of GPIO21 to HIGH.

5.1.1.1.2. Setting the GPIO as an Input

Refer to the following example for how to configure the GPIO as an input.

- Enter the following commands:
 - **AT+WIOM=1,"GPIO21",0** → this command activates GPIO21 as an input.
 - **AT+WIOR="GPIO21"** → this command reads the GPIO21 level and returns the value "1" which represents a HIGH level.
- Pull the GPIO21 pin to GND, and read again. The return value should now be "0" which represents a LOW level.

Refer to documents [1] Open AT Application Framework AT Commands Interface Guide and [2] AirPrime SL808xT and Q2698 Open AT Framework Commands Interface Guide for more information regarding AT commands.

Note: The **AT+WIOW** and **AT+WIOR** commands will automatically set the GPIO to the desired mode. For example, **AT+WIOW=42,1** will set GPIO42 to output mode and in High state.

5.1.1.2. ON/OFF Pin

The FX Series has an external ON/OFF pin which is used to turn the device ON or OFF. The following table describes the operation of this pin.

Table 11. ON/OFF Pin Operation

Condition	State	Power Supply	Operation
1	Open	When 4.75V to 32V supply is applied.	The FX Series is turned ON.
2	Pulled to GND	When 4.75V to 32V supply is applied.	The FX Series remains OFF.
3	Left open when turning ON the FX Series, then pulled to GND	4.75V to 32V supply is initially applied.	The FX Series remains ON and will remain ON until AT+CPOF is sent to turn the device OFF.

To enable the low power mode, the user may simply pull the ON/OFF pin to GND and send **AT+CPOF** to the FX Series using a communication software such as a HyperTerminal.

Table 12. ON/OFF Pin Description

Pin #	Signal	I/O	I/O Voltage	Description
8	ON/OFF	I	4V	Pin to turn the FX Series ON/OFF.

Refer to the power consumption tables in section 11 Power Consumption for the power consumption values when the FX Series is in Alarm mode (Low Power mode).

5.1.2. Serial Interface

A SUB-D 15-pin connector is available as a serial interface to directly communicate with the FX Series. This serial interface is used for:

- RS232 serial link connection
- Audio lines connection (microphone and speaker)
- BOOT signal connection (not used in FX100)
- RESET signal connection

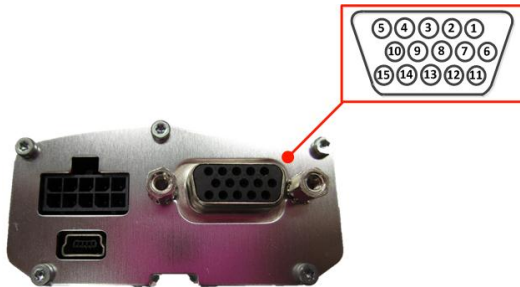

Figure 17. 15-Pin Serial Connector

Refer to the following table for the pin description of the 15-pin serial connector.

Table 13. Serial Connector Pin Description

Pin #	Signal	I/O	I/O Type	Reset State	Description
1	CT109/DCD	O	+/- 5.5V	Undefined	Data Carrier Detect
2	CT103/TXD	I	+/- 5.5V	Z	Transmit Serial Data
3	BOOT*	I	1V8		BOOT. This signal must not be connected. Its use is strictly reserved for Sierra Wireless or competent retailers.
4	CMIC2P	I	Analog		Microphone positive input
5	CMIC2N	I	Analog		Microphone negative input
6	CT104/RXD	O	+/- 5.5V	1	Receive Serial Data
7	CT107/DSR	O	+/- 5.5V	Z	Data Set Ready
8	CT108-2/DTR	I	+/- 5.5V	Z	Data Terminal Ready
9	GND		GND		Ground
10	CSPK2P	O	Analog		Speaker positive input
11	CT106/CTS	O	+/- 5.5V	Z	Clear To Send
12	CT105/RTS	I	+/- 5.5V	Z	Request To Send
13	CT125/RI	O	+/- 5.5V	Undefined	Ring Indicator
14	RESET	I/O	1V8		FX Series Reset
15	CSPK2N	O	Analog		Speaker negative input

* Not used in FX100.

5.1.2.1. RS232 Serial Link Connection

Also known as the main serial link, the RS232 interface performs the voltage level adaptation (V24/CMOS \Leftrightarrow V24/V28) between the internal FX Series (DCE) and external applications (DTE).

The signals available on the RS232 serial link are as follows:

- TX data (CT103/TXD)
- RX data (CT104/RXD)
- Request To Send (CT105/RTS)
- Clear To Send (CT106/CTS)
- Data Terminal Ready (CT108-2/DTR)
- Data Set Ready (CT107/DSR)
- Data Carrier Detect (CT109/DCD)
- Ring Indicator (CT125/RI)

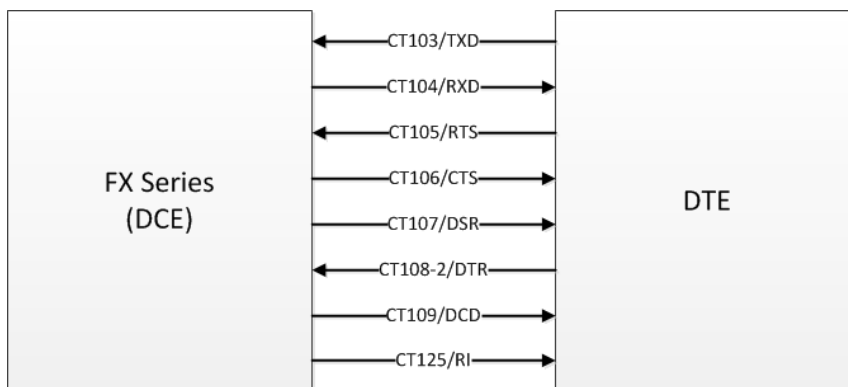

Figure 18. RS232 Serial Link Signals

The RS232 interface has been designed to allow flexibility in the use of the serial interface signals. However, the use of TXD, RXD, CTS and RTS signals are mandatory; while the use of DTR, DSR, DCD and RI signals are optional.

Tip: *The FX Series is designed to operate using all serial interface signals and it is recommended to use CT105/RTS and CT106/CTS for hardware flow control in order to avoid data corruption during transmission.*

The FX Series also implements the Serial Port Auto Shut Down feature with the DTR signal. It is recommended to use the CT108-2/DTR signal to benefit from the current consumption improvement performed by this feature.

5.1.2.2. RS232 Implementation

The following subsections describe how the RS232 serial link can be implemented to suit different designs.

5.1.2.2.1. 5-wire Serial Interface RS232 Implementation

The signals used in this interface are as follows:

- CT103/TXD
- CT104/RXD
- CT105/RTS

- CT106/CTS
- CT108-2/DTR

Note: The CT108-2/DTR signal must be managed following the V24 protocol signaling if the Sleep Idle Mode and Serial Port Auto Shut Down feature are to be used.

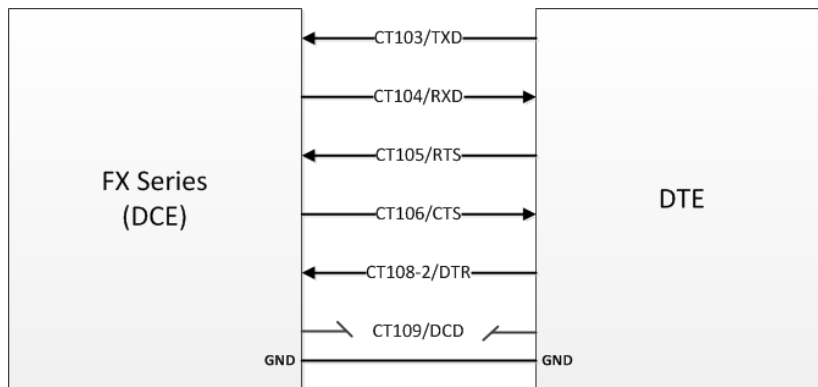

Figure 19. V24 Serial Link Implementation for a 5-wire UART

5.1.2.2.2. 4-wire Serial Interface RS232 Implementation

The signals used in this interface are as follows:

- CT103/TXD
- CT104/RXD
- CT105/RTS
- CT106/CTS

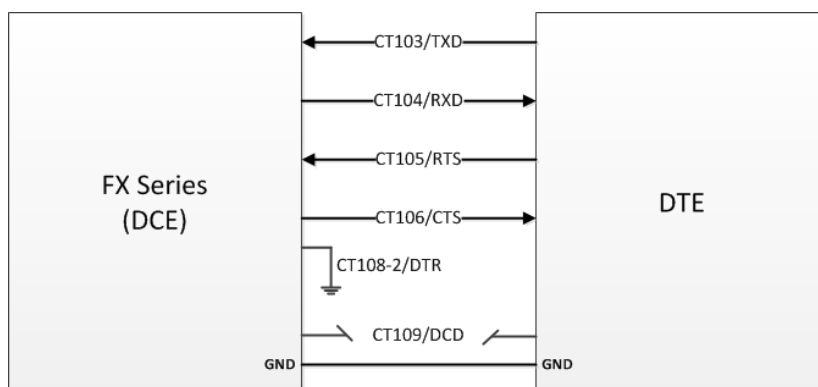

Figure 20. V24 Serial Link Implementation for a 4-wire UART

5.1.2.2.3. 2-wire Serial Interface RS232 Implementation

The signals used in this interface are as follows:

- CT103/TXD
- CT104/RXD

Note: Although this case is possible, it is not recommended.

The flow control mechanism must be managed from the customer end.

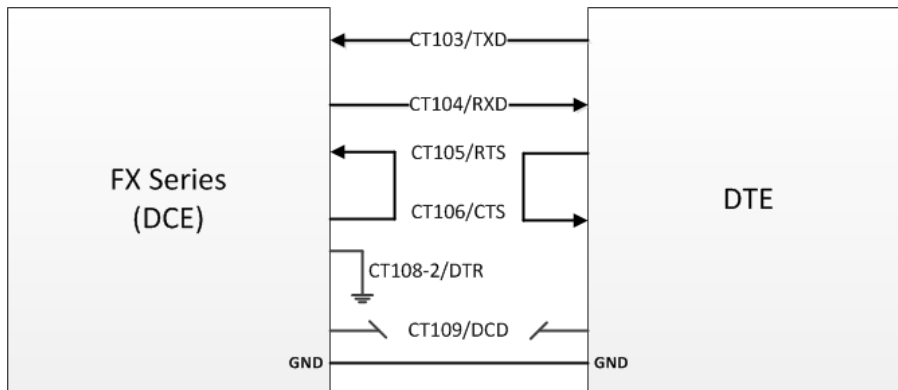

Figure 21. V24 Serial Link Implementation for a 2-wire UART

The CT105/RTS and the CT106/CTS signals are not used in this configuration. Configure the AT command **AT+IFC=0,0** to disable the flow control function. Refer to documents [1] Open AT Application Framework AT Commands Interface Guide and [2] AirPrime SL808xT and Q2698 Open AT Framework Commands Interface Guide for more information regarding AT Commands.

For more information on how to use the RS232 serial link to communicate with the FX Series, refer to section 5.1.2.1 RS232 Serial Link Connection.

5.1.2.3. Autobauding Mode

The autobauding mode allows the FX Series to detect the baud rate used by the DTE connected to the RS232 serial link. The autobauding mode is controlled by AT commands. Refer to documents [1] Open AT Application Framework AT Commands Interface Guide and [2] AirPrime SL808xT and Q2698 Open AT Framework Commands Interface Guide for more information.

5.1.2.4. Serial Port Auto Shut Down Feature

The RS232 serial link can be shut down when there is no activity between the DTE and the FX Series. This can help improve the power consumption performance.

The Serial Port Auto Shut Down feature is controlled by the AT command **AT+WASR**. Enter:

- **AT+WASR=1** to enter the serial port auto shut down mode
- **AT+WASR=0** to exit the serial port auto shut down mode

Refer to documents [1] Open AT Application Framework AT Commands Interface Guide and [2] AirPrime SL808xT and Q2698 Open AT Framework Commands Interface Guide for more information on AT commands.

Caution: *GPIO24 is reserved for serial port auto shut down feature. It is prohibited for customer use. Improper access to GPIO24 by customers may lead to unexpected behavior on serial port performance.*

It is prohibited to use the serial port auto shut down feature when the CT108-2/DTR is not used in the application. Otherwise, there will be data lost from the DTE side to the FX Series.

5.1.2.5. Audio Lines Connection

The FX Series supports one microphone input and one speaker output.

5.1.2.5.1. Microphone

The microphone inputs are connected in differential mode to reject common mode noise and TDMA noise. The microphone inputs have already included biasing for an electrets microphone (0.5mA and 2V) and are ESD protected. An electret microphone may be directly connected to these inputs allowing an easy connection to a headset.

The microphone gain can be adjusted by **AT+VGT** and the transmit digital gain can be adjusted by **AT+WDGT**. Refer to documents [1] Open AT Application Framework AT Commands Interface Guide and [2] AirPrime SL808xT and Q2698 Open AT Framework Commands Interface Guide for more information about these AT commands.

The following table shows the pin assignments of the microphone input. Note that there is a difference in the microphone signal names used between FXT009 and FX100.

Table 14. Microphone Pin Description for FXT009

(Sub D 15-pin) Pin #	Signal	I/O	I/O Type	Description
4	CMIC2P	I	Analog	Microphone positive input
5	CMIC2N	I	Analog	Microphone negative input

Table 15. Microphone Pin Description for FX100

(Sub D 15-pin) Pin #	Signal	I/O	I/O Type	Description
4	CMIC1P	I	Analog	Microphone positive input
5	CMIC1N	I	Analog	Microphone negative input

Table 16. Equivalent Circuits of CMIC

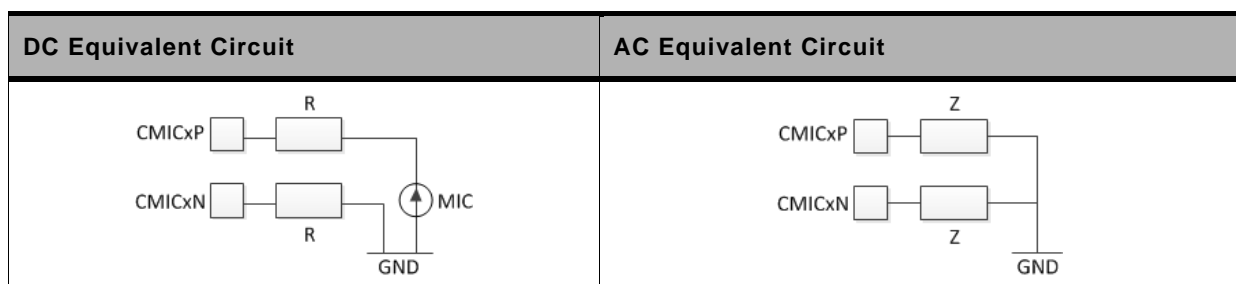

Table 17. Electrical Characteristics of CMIC for FXT009

Parameters		Min	Typ	Max	Unit
Internal biasing DC Characteristics	MIC	2	2.1	2.2	V
	Output current		0.5	1.5	mA
	R	1650	1900	2150	Ω

Parameters		Min	Typ	Max	Unit
AC Characteristics 200 Hz<F<4 kHz	Z CMICxP (CMICxN=Open)	1.1	1.3	1.6	kΩ
	Z CMICxN (CMICxP=Open)				
	Z CMICxP (CMICxN=GND)	0.9	1.1	1.4	
	Z CMICxN (CMICxP=GND)				
	Impedance between CMICxP and CMICxN	1.3	1.6	2	
Working voltage (CMICxP-CMICxN)	AT+VGT*=3500dB		13.8		mVrms
	AT+VGT*=2000dB		77.5		
	AT+VGT*=700dB		346		
Maximum rating voltage (CMICxP or CMICxN)	Positive			+7.35**	V
	Negative	-0.9			

* The input voltage depends of the input micro gain set by AT command. Refer to document [1] Open AT Application Framework AT Commands Interface Guide.

** Because CMICxP is internally biased, it is necessary to use a coupling capacitor to connect an audio signal provided by an active generator. Only a passive microphone can be directly connected to the CMICxP and CMICxN inputs.

Table 18. Electrical Characteristics of CMIC for FX100

Parameters		Min	Typ	Max	Unit
DC Characteristics			N/A		V
AC Characteristics 200 Hz<F<4 kHz	Z	70	120	160	kΩ
Working voltage (CMICxP-CMICxN)	AT+VGT*=3500dB		13.8		mVrms
	AT+VGT*=2000dB		77.5		
	AT+VGT*=700dB		346		
Maximum rating voltage (CMICxP or CMICxN)	Positive			+7.35**	V
	Negative	-0.9			

* The input voltage depends of the input micro gain set by AT command. Refer to document [2] AirPrime SL808xT and Q2698 Open AT Framework Commands Interface Guide.

** Because CMICxP is internally biased, it is necessary to use a coupling capacitor to connect an audio signal provided by an active generator. Only a passive microphone can be directly connected to the CMICxP and CMICxN inputs.

Refer to the following table for the list of recommended microphone characteristics.

Table 19. Recommended Microphone Characteristics

Feature	Values
Type	Electret 2V/0.5 mA
Impedance	Z = 2kΩ
Sensitivity	-40dB to -50dB
SNR	> 50dB
Frequency response	Compatible with GSM specifications

5.1.2.5.2. Speaker

The speaker outputs are connected in differential mode to reject common mode noise and TDMA noise.

Speaker outputs are connected to internal push-pull amplifiers and may be loaded down with components between 32 – 150Ω and up to 1nF. These outputs may be directly connected to a speaker.

The output power may be adjusted by 2dB steps. The gain of the speaker outputs is internally adjusted and may be tuned using the **AT+VGR** command. Furthermore, the digital gain can be adjusted using **AT+WDGR**. Refer to documents [1] Open AT Application Framework AT Commands Interface Guide and [2] AirPrime SL808xT and Q2698 Open AT Framework Commands Interface Guide for more information about these AT commands.

The following table shows the pin assignments of the speaker output. Note that there is a difference in the speaker signal name used between FXT009 and FX100.

Table 20. Speaker Outputs Pin Description for FXT009

(Sub D 15-pin) Pin #	Signal	I/O	I/O Type	Description
10	CSPK2P	O	Analog	Speaker positive output
15	CSPK2N	O	Analog	Speaker negative output

Table 21. Speaker Outputs Pin Description for FX100

(Sub D 15-pin) Pin #	Signal	I/O	I/O Type	Description
10	CSPK1P	O	Analog	Speaker positive output
15	CSPK1N	O	Analog	Speaker negative output

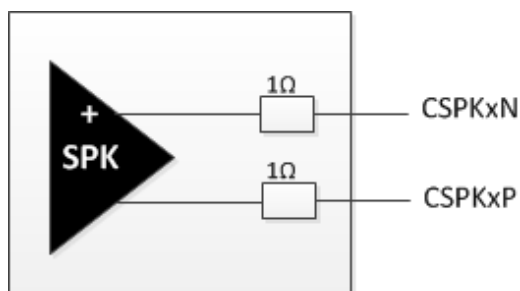

Figure 22. Equivalent Circuit of CSPK

Table 22. Electrical Characteristics of CSPK for FXT009

Parameters		Min	Typ	Max	Unit
Biasing voltage	CSPKxP and CSPKxN		1.30		V
Output swing voltage	RL=8Ω: AT+VGR=-1000*; differential	-	-	4	Vpp
	RL=32Ω: AT+VGR=-1000*; differential	-	-	5	Vpp
RL	Load resistance	6	8	-	Ω

Parameters		Min	Typ	Max	Unit
IOUT	Output current; peak value; RL=8Ω	-	-	180	mA
POUT	RL=8Ω; AT+VGR=-1000*;	-	-	250	mW
RPD	Output pull-down resistance at power-down	28	40	52	kΩ
VPD	Output DC voltage at power-down	-	-	100	mV

* The output voltage depends of the output speaker gain set by AT command. Refer to document [1] Open AT Application Framework AT Commands Interface Guide. This value is given in dB, but it's possible to toggle this to index value.

Table 23. Electrical Characteristics of CSPK for FX100

Parameters		Min	Typ	Max	Unit
Biasing voltage	CSPKxP and CSPKxN	-1.5		1.5	mV
Output swing voltage	RL=16Ω; AT+VGR=-1600*; single-ended	-	1.7		Vpp
	RL=32Ω; AT+VGR=-1600*; single-ended	-	1.9	2.75	Vpp
RL	Load resistance	14.5	32	-	Ω
IOUT	Output current; peak value; RL=16Ω	-	40	85	mA
	Output current; peak value; RL=32Ω	-	22	-	mA
POUT	RL=16Ω; AT+VGR=-1600*	-	25	-	mW
	RL=32Ω; AT+VGR=-1600*	-	16	27	mW
RPD	Output pull-down resistance at power-down	28	40	52	kΩ

* The output voltage depends of the output speaker gain set by AT command. Refer to document [2] AirPrime SL808xT and Q2698 Open AT Framework Commands Interface Guide. This value is given in dB, but it's possible to toggle this to index value.

Refer to the following table for the list of recommended speaker characteristics.

Table 24. Recommended Speaker Characteristics

Feature	Values
Type	10mW, electro-magnetic
Impedance	Z = 30 to 50Ω
Sensitivity	110dB SPL min. (0dB = 20μPa)
Frequency response	Compatible with GSM specifications

5.1.3. USB Interface

Aside from the serial interface, the Mini-B USB interface (USB slave) may also be used to directly communicate with the FX Series.

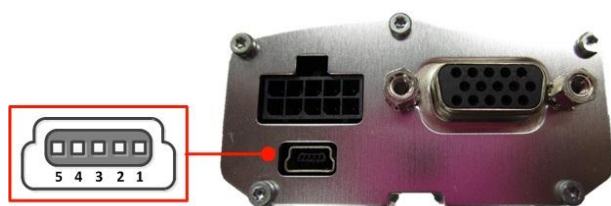

Figure 23. Mini-B USB Connector

Refer to the following table for the pin description of the mini-B USB connector.

Table 25. Mini-B USB Pin Description

Pin #	Signal	Description
1	VBUS	+5V Power supply
2	D-	Differential data interface negative
3	D+	Differential data interface positive
4	ID	Not connected
5	GND	Ground

The FXT009 USB slave interface complies with USB 2.0 protocol signaling but not with USB 2.0 electrical interface; while the FX100 can support both USB 2.0 protocol signaling and electrical interface.

The USB interface features:

- 12Mbit/s full speed transfer rate for FXT009; 480Mbit/s high-speed transfer rate for FX100
- 3.3V type compatible
- USB Soft-connect feature
- USB Download feature (only supported by FX100)
- CDC 1.1 – ACM compliant

Table 26. USB Electrical Characteristics for FXT009

Parameter	I/O	Min	Typ	Max	Unit
VBUS	I	4.75	5		V
D-, D+	I/O	3	3.3	3.6	V
VBUS Input current consumption				100	mA

Table 27. USB Electrical Characteristics for FX100

Parameter	I/O	Min	Typ	Max	Unit
VBUS	Input	4.75	5		V
D-, D+ (Low / Full speed)	Input High	2.00	3.30	3.60	V
	Input Low	0		0.80	V
	Output High	2.80	3.30	3.60	V
	Output Low			0.30	V
D-, D+ (High speed)	Input High	0.30		0.44	V
	Input Low	0		0.01	V
	Output High	0.36	0.38	0.44	V
	Output Low	0		0.01	V

The USB feature can be activated by using the **AT+WMFM=0,1,3** AT command. Refer to documents [1] Open AT Application Framework AT Commands Interface Guide and [2] AirPrime SL808xT and Q2698 Open AT Framework Commands Interface Guide for more information regarding this AT command.

5.2. Back Interface

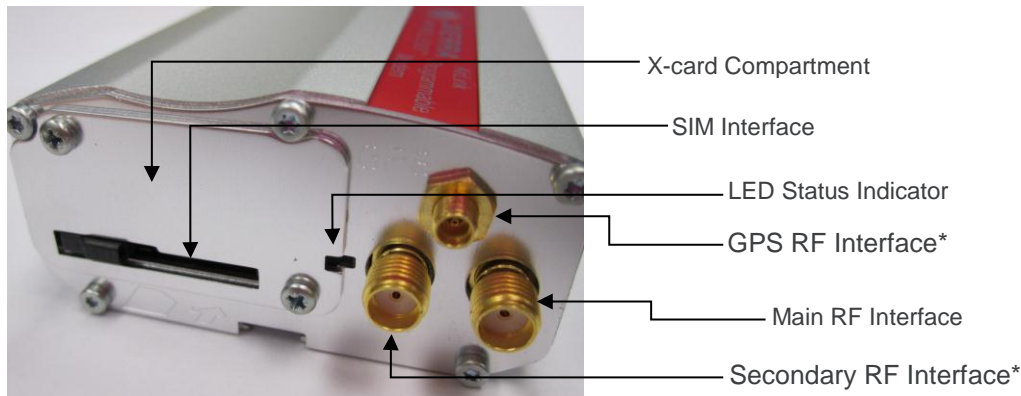

Figure 24. FX Series Back Interface

Note: * The secondary and GPS RF interfaces are only available for FX100.

5.2.1. SIM Interface

A SIM card can be directly connected to the FX Series through the embedded SIM socket. This interface controls 3V / 1V8 SIM cards and it is fully compliant with GSM 11.11 recommendations concerning SIM functions.

The SIM interface of the FX Series is ESD protected. Transient overvoltage protections in ESD are internally added on the signals connected to the SIM interface in order to prevent any damage from electrostatic discharge.

The SIM interface uses 5 SIM signals, namely:

- SIM-VCC: SIM Power supply
- ~SIM-RST: Reset
- SIM-CLK: Clock
- SIM-IO: I/O Port
- SIMPRES: SIM card detection

5.2.1.1. SIM Socket Pin Description

Refer to the following table for the pin description of the SIM socket.

Table 28. SIM Socket Pin Description

Pin #	Signal	I/O	I/O Type	Reset State	Description
1	SIMVCC	O	2V9 / 1V8		SIM Power Supply
2	SIMRST	O	2V9 / 1V8	O	SIM RESET
3	SIMCLK	O	2V9 / 1V8	O	SIM Clock
7	SIMDATA	I/O	2V9 / 1V8	Pull up*	SIM DATA
8	SIMPRES	I	1V8	Pull low**	SIM Card Detect

* SIM-IO pull up is about 10KΩ.

** SIMPRES pull low is about 100KΩ.

5.2.2. RF Interface

The FX Series can have up to three RF interfaces, depending on the variant. Refer to the following table for the list of available RF interfaces per FX Series variant.

Table 29. Available RF Interface

FX Series Variant	Main RF Interface	Secondary RF Interface	GPS RF Interface
FXT009	✓		
FX100	✓	✓	✓

The main antenna connector allows the transmission of radio frequency (RF) signals from the device to an external customer supplied antenna. This interface is an SMA type connector and its nominal impedance is 50Ω.



Figure 25. Main RF Connector

The secondary RF interface is used in FX100 for 3G diversity antenna connection. It is an SMA type connector and its nominal impedance is 50Ω.

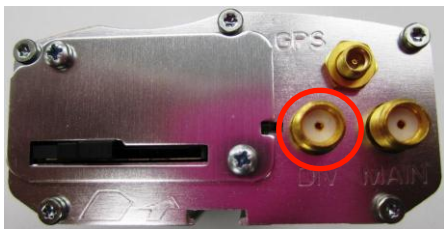

Figure 26. Secondary RF Connector for FX100

The GPS RF interface is only available in the FX100 and is used for GPS antenna connection. It is an MMCX type connector and its nominal impedance is 50Ω. It also provides bias for active antenna. For more details, refer to section 5.2.2.3.6 Active GPS Antenna Bias.



Figure 27. GPS RF Connector for FX100

5.2.2.1. RF Performances

RF performances are compliant with ETSI recommendation GSM 05.05. Refer to the tables below for the main parameters used for both the Receiver and the Transmitter.

Table 30. Main Receiver Parameters for FXT009

Parameters	Typical Values
GSM850 Reference Sensitivity	-106dBm
E-GSM900 Reference Sensitivity	-106dBm
DCS1800 Reference Sensitivity	-106dBm
PCS1900 Reference Sensitivity	-106dBm
Selectivity @ 200 kHz	> +9dBc
Selectivity @ 400 kHz	> +41dBc
Linear dynamic range	63dB
Co-channel rejection	>= 9dBc

Table 31. Main Transmitter Parameters for FXT009

Parameters	Typical Values
Output power at PCL5 (EGSM & GSM850)	33dBm
Output power at PCL0 (GSM1800 & PCS1900)	30dBm
Output power at PCL19 (EGSM & GSM850)	5dBm
Output power at PCL15 (GSM1800 & PCS1900)	0dBm

Table 32. Main Receiver Parameters for FX100

Parameters	Typical Values
GSM850 Reference Sensitivity	-108dBm
E-GSM900 Reference Sensitivity	-109dBm
DCS1800 Reference Sensitivity	-107dBm
PCS1900 Reference Sensitivity	-107dBm
3G Band I 2100 Reference Sensitivity	-108dBm
3G Band II 1900 Reference Sensitivity	-107dBm
3G Band V 850 Reference Sensitivity	-110dBm
3G Band VI 800 Reference Sensitivity	-110dBm
3G Band VIII 900 Reference Sensitivity	-108dBm
Selectivity @ 200 kHz	> +9dBc
Selectivity @ 400 kHz	> +41dBc
Linear dynamic range	63dB
Co-channel rejection	>= 9dBc

Table 33. Main Transmitter Parameters for FX100

Parameters	Typical Values
Output power at PCL5 (EGSM & GSM850)	32dBm

Parameters	Typical Values
Output power at PCL0 (GSM1800 & PCS1900)	29dBm
Output power at PCL19 (EGSM & GSM850)	5dBm
Output power at PCL15 (GSM1800 & PCS1900)	0dBm
Output power Class 3 (3G all band)	23dBm

5.2.2.2. Antenna Specifications

The main/secondary antenna must meet the requirements specified in the table below.

The optimum operating frequency depends on the application. A dual-band or quad-band antenna should operate in these frequency bands and have the following characteristics.

Antennas used with the FX100 must have a minimum antenna gain of 1 dBi for Bands 900 and 1800, and 2.5 dBi for Band 2100.

Table 34. Antenna Specifications for FXT009 and FX100

Characteristics	GSM850 and WCDMA Band V	WCDMA Band VI	EGSM 900 and WCDMA Band VIII	DCS 1800	PCS 1900 and WCDMA Band II	WCDMA Band I
TX Frequency	824 to 849 MHz	830 to 840 MHz	880 to 915 MHz	1710 to 1785 MHz	1850 to 1910 MHz	1920 to 1980 MHz
RX Frequency	869 to 894 MHz	875 to 885 MHz	925 to 960 MHz	1805 to 1880 MHz	1930 to 1990 MHz	2110 to 2170 MHz
Impedance	50Ω					
VSWR	Rx max	1.5:1				
	Tx max	1.5:1				
Typical radiated gain	0dBi in one direction at least					

Note: WCDMA bands I, II, V, VI and VIII are only available in FX100.

The FX100 GPS antenna must meet the requirements specified in the table below.

Table 35. GPS Antenna Specifications for FX100

Characteristic	GPS L1
RX Frequency	1575.42 MHz
RF Impedance	50Ω
VSWR	Rx max
	1.5:1
LNA Bias Voltage	5V
LNA Current Consumption	40mA MAX
Polarization	Linear, vertical
Typical radiated gain	0dBi in one direction at least

5.2.2.3. GPS Specifications for FX100

Note: These specifications are preliminary targets that are subject to change without notice. Actual GPS functionality depends on the firmware version and module configuration.

The FX100 provides the GPS features listed in the following sub-sections. This GPS feature can be used through AT commands provided by the Extended Open AT application (which is pre-loaded at the factory) or from a custom Open AT application using Location Library.

5.2.2.3.1. Standalone GPS

- Leading standalone/autonomous GPS performance
- -145 dBm cold start sensitivity
- -153 dBm hot start sensitivity
- -155 dBm tracking sensitivity
- < 45 second average cold start TTFF (Time To First Fix) in open air
- < 3 second average super hot TTFF in open sky
- < 10 m accuracy in open sky

Note: For optimum performance, the modem should be registered on the GSM/UMTS network, but does not need to be on an active data or voice call.

5.2.2.3.2. gpsOneXTRA™

- Enables enhanced standalone GPS operation by downloading < 40 kB file from a server on the Internet
- Performance closer to UE-based operation than traditional standalone GPS operation
- Best if downloaded once every 1–2 days, but valid for up to 7 days with some accuracy degradation

5.2.2.3.3. A-GPS Features

- Leading A-GPS performance
Exceeds 3GPP RAN 4 AGPS performance specification
- -153 dBm cold start sensitivity
- -155 dBm tracking sensitivity
- < 5 second average cold start TTFF in open sky (UE-based)
- < 3 second average super hot TTFF in open sky
- < 2 m accuracy in open sky 1 Hz tracking with CEP-50
- UMTS Control Plane (CP) – UE-assisted and UE-based
- GSM Control Plane (CP) – UE-assisted and UE-based

5.2.2.3.4. Enhanced Navigation 2.0 Feature

- Provides leading performance in car and walking navigation modes as well as accuracy while stationary
- Airline/Game/Offline mode
- GPS capability is available while phone is offline

5.2.2.3.5. NMEA

Supported sentences: GGA, GSA, GSV, RMC, VTG

5.2.2.3.6. Active GPS Antenna Bias

The FX100 provides bias for active antenna, which can be enabled or disabled using GPIO44. Note that GPIO44 needs to be at high level for antenna bias to be activated.



6. Signals and Indicators

6.1. Alarm Mode

The FX Series can be turned on using the Alarm mode when power supply is applied. The FX Series will remain in Low Power mode until the alarm is triggered to start the FX Series up.

Note: Refer to section 5.1.1.2 ON/OFF Pin for more information on how to turn the FX Series ON or OFF using the ON/OFF pin.

Table 36. Alarm Mode (Low Power Mode)

Steps	State	Power Supply	Operation
1	AT+CALA="YY/MM/DD,H H:MM"	4.75V to 32V supply is applied.	The alarm is set. The FX Series remains ON.
2	Pulled ON/OFF PIN to GND	4.75V to 32V supply is applied.	The FX Series remains ON.
3	AT+CPOF	4.75V to 32V supply is applied. (The ON/OFF signal remains at GND.)	The FX Series turns OFF and will remain OFF until the Alarm mode is activated to turn the device ON.

Note: The FX Series' clock must be set before Alarm mode is activated. To set the clock, refer to the **AT+CCLK** command of documents [1] Open AT Application Framework AT Commands Interface Guide and [2] AirPrime SL808xT and Q2698 Open AT Framework Commands Interface Guide.

6.2. BOOT Signal Connection (FXT009 only)

A specific control pin, BOOT, is available to download to the FXT009. Specific PC software, provided by Sierra Wireless, is needed to perform this download, specifically for the first download of the Flash memory.

Caution: This signal must not be connected. Its use is strictly reserved for Sierra Wireless or competent retailers.

6.3. RESET Signal Connection

This signal is used to force a reset procedure by providing the FX Series with a LOW level that lasts at least 200µs (when the power supply is already stabilized). It is activated by either an external Reset signal or by an internal signal (from the Reset generator); and is automatically driven by an internal hardware during the power ON sequence.

Note: The FX Series remains in Reset mode for as long as the Reset signal is held LOW.

A software reset is always preferred to a hardware reset. Refer to document documents [1] Open AT Application Framework AT Commands Interface Guide and [2] AirPrime SL808xT and Q2698 Open AT Framework Commands Interface Guide for more information regarding software resets.

This signal may also be used to provide a reset to an external device when the pin is configured as an output. If no external reset is necessary, this input may be left open.

When used (as an emergency reset), it has to be driven by either an open collector or an open drain output.

Caution: *This signal is for emergency resets only.*

Table 37. FX Series Reset Status

(Serial Port) Pin #	Signal	I/O	I/O Type	Voltage	Description
14	Reset	I/O	Open drain	1V8	FX Series Reset

Table 38. Reset Electrical Characteristics For FXT009

Parameter	Minimum	Typical	Maximum	Unit
Input Impedance (R)*		100.3		kΩ
Input Impedance (C)		40		nF

* Internal pull-up

Table 39. Reset Electrical Characteristics for FX100

Parameter	Minimum	Typical	Maximum	Unit
Input Impedance (R)*		10		kΩ
Input Impedance (C)		20		nF

* Internal pull-up

Table 40. Reset Operating Conditions

Parameter	Minimum	Typical	Maximum	Unit
~Reset time (Rt) ¹	200			μs
~Reset time (Rt) ² (at power up only)	20	40	100	ms
Cancellation time (Ct)		34		ms
V _H *	0.57			V
V _{IL}	0		0.57	V
V _{IH}	1.33			V

* V_H = Hysteresis Voltage

1 This reset time is the minimum to be carried out on the ~Reset signal when the power supply is stabilized.

2 This reset time is internally carried out by the embedded module power supply supervisor only when the embedded module power supplies are powered ON.

6.3.1. Reset Sequence

To activate the Reset sequence, the Reset signal has to be set to LOW for a minimum of 200μs. As soon as the reset is done, the application can send the command **AT+J** and the AT interface will send an "OK" back to the application. If the application manages hardware flow control, the AT command may be sent during the initialization phase.

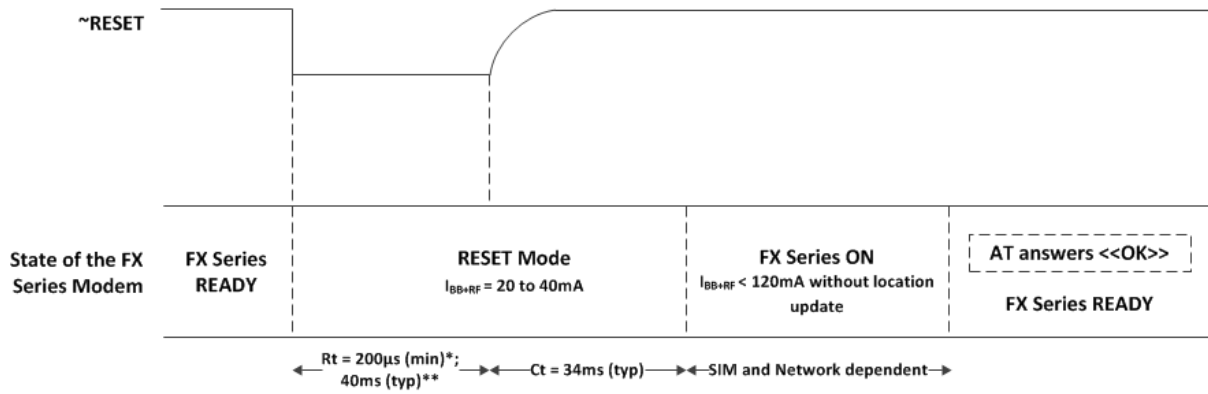

- * This reset time is the minimum time to be carried out on the ~RESET signal when the power supply is already stabilized.
- ** This reset time is internally carried out by the power supply supervisor only when the FX Series power supplies are powered ON.

Figure 28. Reset Sequence Diagram

Another solution is to use the **AT+WIND** command to get an unsolicited status from the FX Series. Refer to documents [1] Open AT Application Framework AT Commands Interface Guide and [2] AirPrime SL808xT and Q2698 Open AT Framework Commands Interface Guide for more information regarding AT commands.

6.4. LED Status Indicator

The FX Series has a red LED that indicates the current operational status of the device.

Table 41. FX Series LED Status

FX Series State	LED Status	FX Series Status
ON	Permanently lighted	The FX Series is switched ON, but not registered in the network.
	Flashing slowly LED is ON for 200ms, OFF for 2s	The FX Series is switched ON and is registered in a network (Idle mode).
	Flashing rapidly LED is ON for 200ms, OFF for 600ms	The FX Series is switched ON and is registered in a network (Connected mode).
	Very quick flash LED is ON for 100ms, OFF for 200ms	The FX Series is switched on, and the software downloaded is either corrupted or non-compatible ("BAD SOFTWARE").
	OFF	OFF

* The Flash LED can be disabled by the user when in Sleep mode in order to save power consumption. Refer to section 9.8 Enabling/Disabling the Flash LED and documents [1] Open AT Application Framework AT Commands Interface Guide and [2] AirPrime SL808xT and Q2698 Open AT Framework Commands Interface Guide for more information on how to disable the Flash LED using an AT command.

6.5. Real Time Clock (RTC)

The FX Series has implemented Real Time Clock for saving date and time when the FX Series is unplugged from the DC power supply through the DC power cable.

Table 42. Real Time Clock Specifications

Item	Minimum	Typical	Maximum
Charging Time start from fully discharged to fully charged		15 Hours	
RTC Time Period*	Guaranteed	30 Hours	
	Not guaranteed	60 Hours	

* This RTC time period is measured when the RTC battery is fully charged before the FX Series is unplugged from the DC power source.

* This RTC time period is for temperature from -20°C to +60°C. Once the operating/storage temperature is beyond this range, this time period is not guaranteed.

Caution: *When the FX Series is shipped out, the charging voltage of the RTC battery is not guaranteed. Once the FX Series is on power, the RTC battery will start charging and the RTC feature can then be resumed.*

6.6. Interrupt

An interrupt pin, INT1, is multiplexed with GPIO25 on pin 1 of the Microfit connector. Additional interrupt pins are also available via the X-card connector. Refer to the following table for the list of available interrupt pins in the FX series.

Table 43. Available Interrupt Pins on the FX Series

Interface Location	Pin Number	Signal Name	Multiplex	Notes
Microfit connector	1	INT1	GPIO25	
X-card connector	23	INT4	RXD2	Only available in the FXT009
X-card connector	32	INT0	GPIO3	

>> 7. X-card

7.1. X-card Compartment

The X-card compartment allows users to easily expand the FX Series' features (Ethernet, for example) for their own applications.

7.1.1. Back Plate Screws

Unscrew the two back plate screws to remove the back plate and open the X-card compartment.

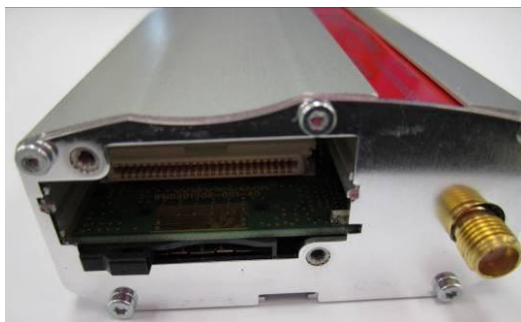

Figure 29. FX Series X-card Compartment

7.1.2. 50-pin X-card Connector

The high density 50-pin X-card connector is used for interfacing the X-card with the FX Series motherboard.

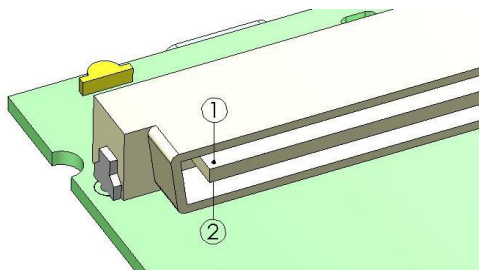

Figure 30. 50-pin X-card Connector

Table 44. 50-pin X-card Connector Description

Pin #	Pin Description	Pin #	Pin Description
1	GND	26	RTS2
2	GND	27	Reserved
3	Reserved	28	GPIO26
4	Reserved	29	GPIO19
5	Reserved	30	GPIO27
6	Reserved	31	GPIO20
7	NC	32	INT0/GPIO3

Pin #	Pin Description	Pin #	Pin Description
8	NC	33	GPIO23
9	NC	34	GPIO22
10	1.8V Digital supply from the embedded module	35	DTR1-CT108/2
11	2.8V Digital supply from the embedded module	36	PCM-SYNC
12	BOOT*	37	PCM-IN
13	RESET	38	PCM-CLK
14	AUX-ADC	39	PCM-OUT
15	SPI1-CS	40	AUX-DAC*
16	SPI1-CLK	41	2.8V supply from the FX Series
17	SPI1-I	42	GND
18	SPI1-IO	43	DC-IN
19	SPI2-CLK	44	DC-IN
20	SPI2-IO	45	GND
21	SPI2-CS	46	4V supply from the FX Series
22	SPI2-I	47	4V supply from the FX Series
23	RXD2/INT4**	48	GND
24	TXD2	49	GND
25	CTS2	50	GND

* Not used in the FX100.

** The multiplexed interrupt pin is only available in FXT009

7.2. X-card Physical Description

Refer to the figure below for the physical dimensions of the X-card.

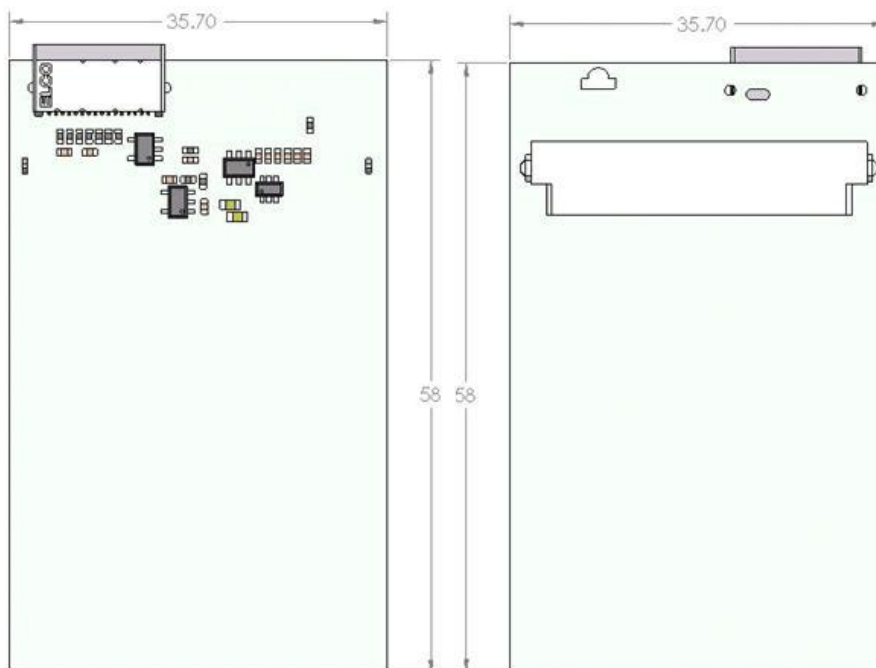

Figure 31. X-card Size

7.3. X-card Design Suggestion

Refer to the following diagram for suggested dimensions when using a customized X-card.

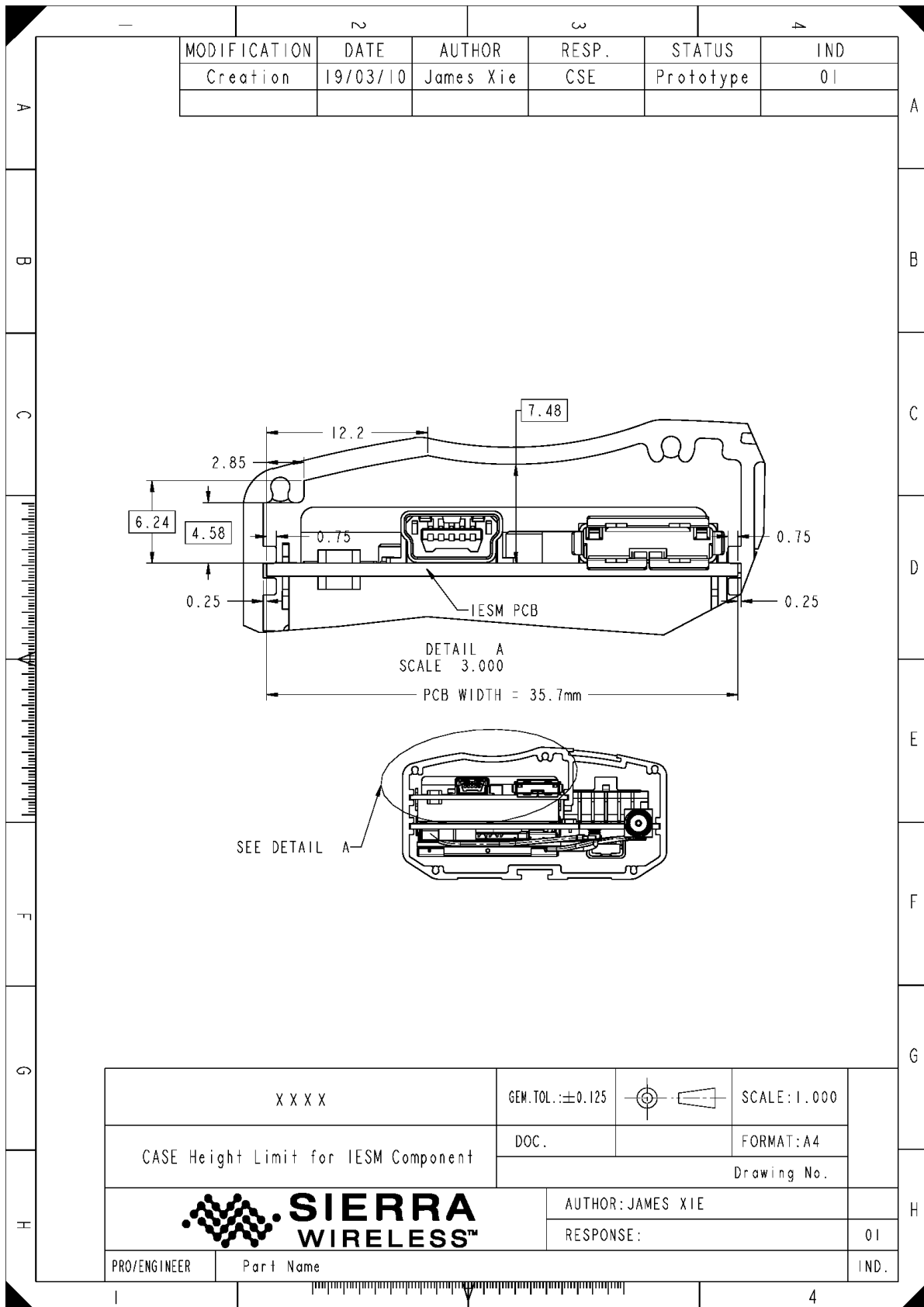

Figure 32. Suggested X-card Dimension

7.4. FXTE02

Sierra Wireless manufactures an Ethernet X-card called FXTE02 which is supported by the FX Series. The basic features of the FXTE02 Ethernet X-card are summarized in the table below.

Table 45. Basic Features of FXTE02 Ethernet X-card

Features	Description
Open AT Application Framework	Open AT Application Framework programmable: <ul style="list-style-type: none"> • Native execution of embedded standard ANSI C applications • Custom AT command creation • Custom application library creation • Standalone operation
LAN	<ul style="list-style-type: none"> • IEEE 802.3 Compatible • Integrated MAC and 10 BASE-T PHY • Receiver and collision squelch circuit • Supports one 10BASE-T port • Supports Full and Half-Duplex modes • Shielded RJ-45
Interfaces	<ul style="list-style-type: none"> • AT command set based on V.25 or later and GSM 07.05 & 07.07 • Interface for embedded application

7.4.1. FXTE02 Ethernet X-card Installation

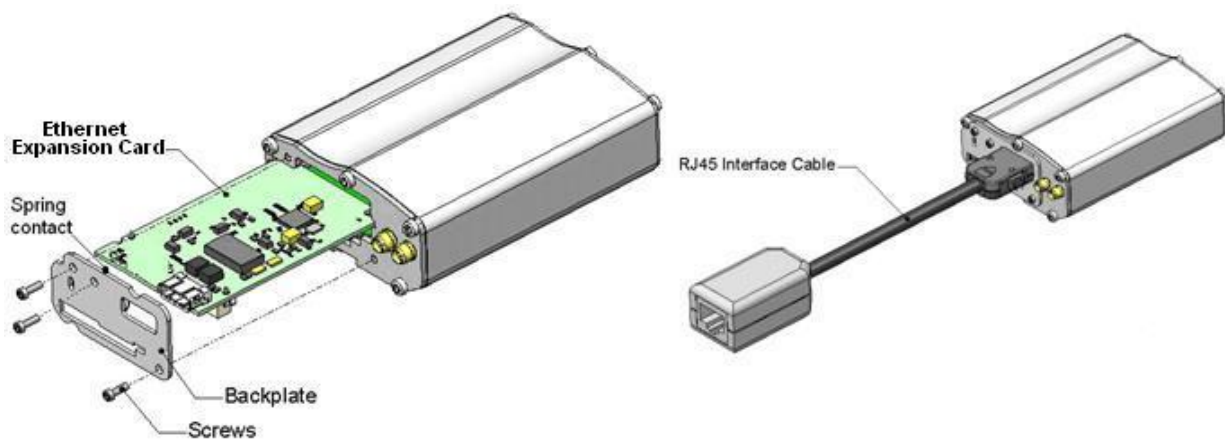

Figure 33. FXTE02 Ethernet X-card Installation on the FX Series

7.4.2. Board Architecture

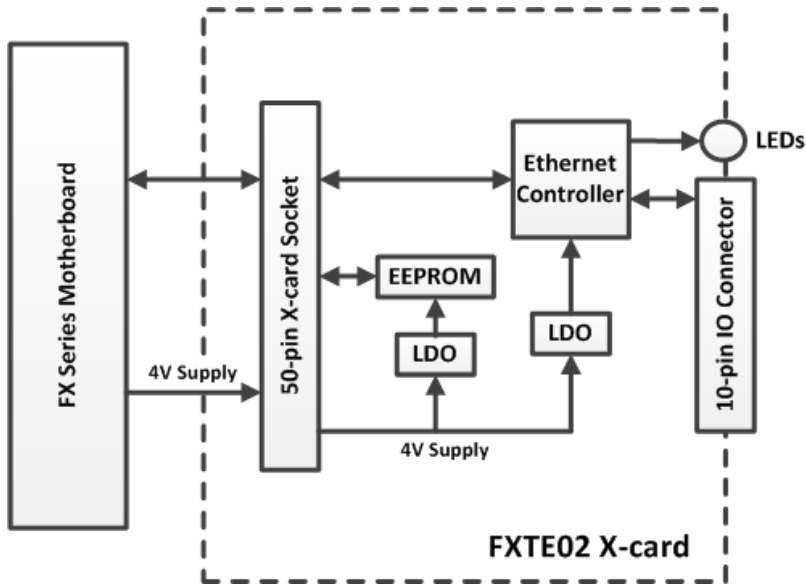

Figure 34. FXTE02 Ethernet X-card Architecture

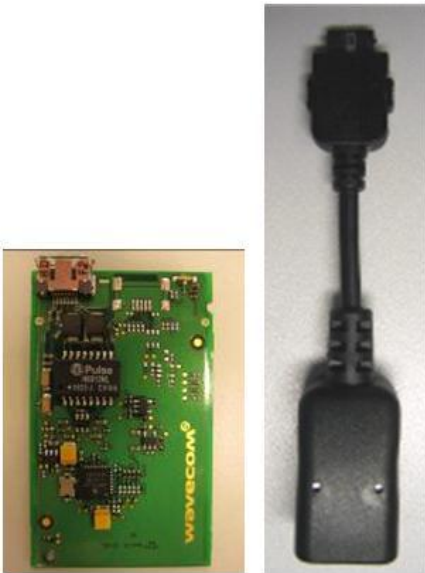

Figure 35. FXTE02 X-card and an RJ-45 Interface Cable

The 10-pin Interface Socket is an external interface for the RJ-45 cable.

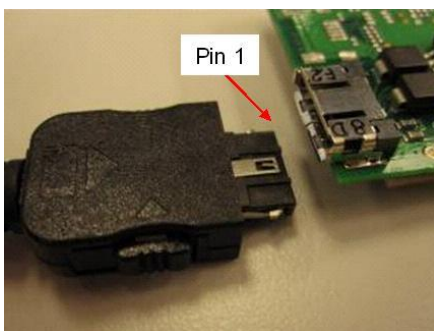

Figure 36. 10-pin Interface Socket

Table 46. 10-pin Interface Socket Description

Pin #	Description Name
1	DGND
2	TX_D1-
3	TX_D1+
4	RX_D2-
5	RX_D2+
6	BI_D3+
7	BI_D3-
8	BI_D4+
9	BI_D4-
10	DGND

7.4.3. Mechanical Characteristics

Table 47. Mechanical Characteristics

PCB Dimensions	58mm x 35.7mm x 1mm
Overall Dimension	59.5 x 35.7 x 10.01mm (including connectors)
Weight	8.5 grams (typical)

7.4.4. Power Supply

Table 48. Electrical Characteristics

Operating Voltage	4V DC
--------------------------	-------

Note: The FXTE02 X-card is powered once the enable pins are activated by the Open AT Application Framework.

7.4.4.1. Extra Current Consumption from the DC-IN Source

Depending on various DC-IN voltages of the FX Series, the extra current consumption drawn by the FXTE02 X-card will also vary.

Table 49. Extra Current Consumption from DC-IN Source (Typical)

Condition		Extra Current Consumption for Additional Feature (mA)		
FX Series Mode	Ethernet Feature	@4.75VDC	@13.2VDC	@32VDC
Connected	Enabled Idle	163mA	53.7mA	20.8mA
Non-Connected	Enabled Idle	171.7mA	49.6mA	24.0mA

7.5. X-card Removal

To remove the X-card from the FX Series, insert the extraction tool hook into the X-card extraction hole located under the PCB. Once in place, pull the extraction tool to extract the X-card from the FX Series.

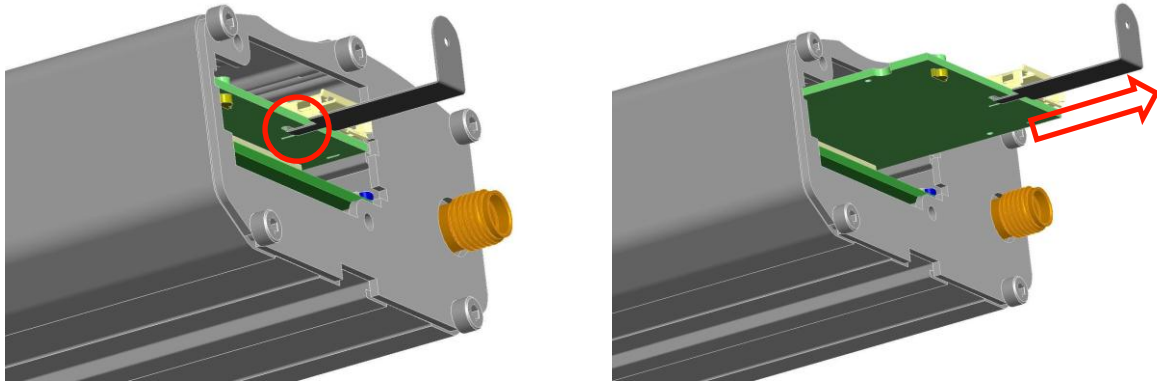

Figure 37. X-card Removal Procedure

8. Using the FX Series

8.1. Mounting the FX Series

The holding bridles help hold and secure the FX Series on a support.



Figure 38. FX Series Holding Bridles

To mount the FX Series on its support, bind it using the holding bridles as shown in the figure below.

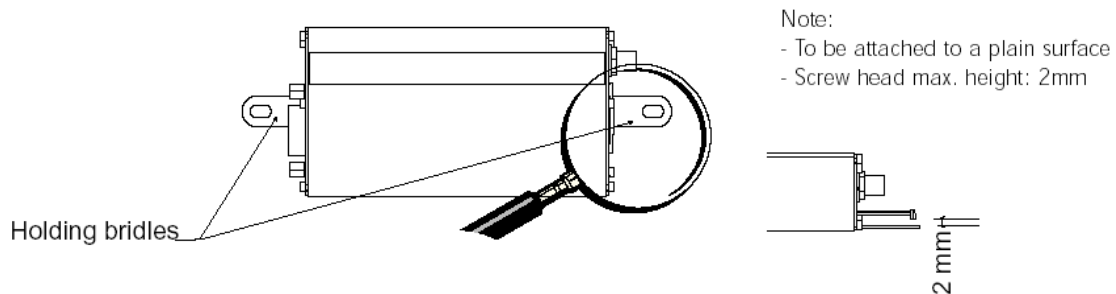

Figure 39. Mounting the FX Series

For more information on the drill template, refer to section 4.2 Mechanical Specifications.

8.2. Getting Started

To set up the FX Series, follow the procedures below.

1. Insert the SIM card into the SIM card socket.
(Refer to [Inserting the SIM Card](#) and [Extracting the SIM Card](#) for more details on how to insert and extract the SIM card from the FX Series.)



2. Slide the SIM lock switch to lock the SIM card in the FX Series.

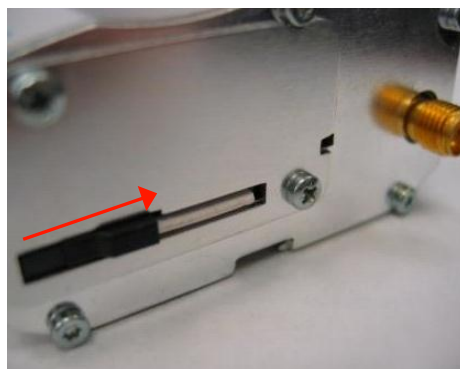

3. Connect the main antenna to the main RF connector.



4. Connect the secondary antenna to the diversity RF connector.

Note: This step is only applicable to the FX100.



5. Connect the GPS antenna to the GPS RF connector.

Note: This step is only applicable to the FX100.



6. Connect the serial cable and screw both sides.



7. Connect the USB cable.



8. Plug the 6-wire cable accessory into the FX Series and switch on the external power supply source.



Refer to section 9.10 Main AT Commands for the FX Series for the list of main AT Commands used to configure the FX Series.

Note: For automotive applications, it is recommended to connect the DC-IN line of the FX Series directly to the positive terminal of the battery.

8.2.1. Inserting the SIM Card

In order to insert the SIM card into the FX Series, follow the procedures below:

1. Prepare the SIM card in the correct position as shown in the figure.



2. Slide the SIM card into the SIM holder.



3. Use a tool to help push the SIM card into the SIM holder. Push the SIM card all the way in until you hear a clicking sound.



4. Slide the SIM lock switch to lock the SIM card in the FX Series.

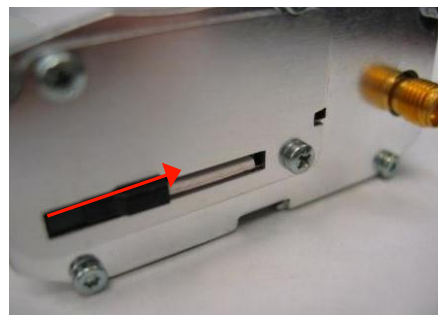

8.2.2. Extracting the SIM Card

In order to extract the SIM card from the FX Series, follow the procedures below:

1. Open the SIM lock switch by sliding it to the left.

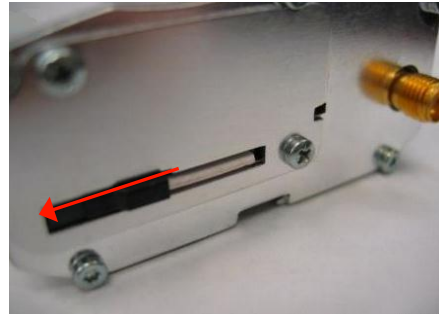

2. Use a tool to further push the SIM card into the SIM holder. Push until you hear a clicking sound.



3. The SIM card should spring out a little bit after the clicking sound.



4. Extract the SIM card from the FX Series.



8.3. Using the FX Series with an X-card

Refer to section 7 X-card for more information about using the FX Series with an X-card.

Refer to section 17.2 X-card Documentation for the list of documents containing additional information on how to use the X-card with the FX Series.

8.4. Operational Status

The FX Series' operational status is defined by a red LED, which is located between the back plate and the secondary RF interface. Refer to section 6.4 LED Status Indicator for more information about the LED status indicator.



9. Communicating with the FX Series

After setting up the FX Series, communications can be established by directly sending AT commands to the device using terminal software such as HyperTerminal for MS Windows. The following subsections describe how this is done.

For more information about the AT commands described in the following sub-sections, refer to documents [1] Open AT Application Framework AT Commands Interface Guide and [2] AirPrime SL808xT and Q2698 Open AT Framework Commands Interface Guide.

9.1. Communications Testing

To perform a communications test after the FX Series has been setup using the RS232 serial link connection, do the following:

- Connect the RS232 link between the external application COM port (DTE) and the FX Series (DCE).
- Configure the RS232 port of the DTE as follows:
 - COM port: 1 (commonly used port for PC serial)
 - Bits per second: 115200 bps
 - Data bits: 8
 - Parity: None
 - Stop bits: 1
 - Flow control: Hardware
- Using a communication software such as HyperTerminal, enter:
AT↵
- When communications have been established, the FX Series will respond with an "OK", which is displayed in the HyperTerminal window.

If communications cannot be established with the FX Series, do the following:

- Check the RS232 connection between the application (DTE) and the FX Series (DCE).
- Check the configuration of the COM port used on the DTE.

Refer to the table below for other AT commands that can be used after getting the FX Series started.

Table 50. Basic AT Commands to Use with the FX Series

AT Command	Description
AT+CGMI	To check if the serial link is OK The FX Series will respond with "Sierra Wireless" when it is OK.*
AT+CPIN=xxxx	To enter a PIN code, xxxx (if activated)
AT+CSQ	To verify the received signal strength
AT+CREG?	To verify the registration of the FX Series on the network
ATD<phone number>;	To initiate a voice call
ATH	To hang up (end of call)

* When using Firmware version R7.43 or older, this command will respond with "WAVECOM WIRELESS CPU" when the serial link is OK.

9.2. Verifying the Received Signal Strength

The FX Series only establishes a call if the received signal strength is strong enough. Using a communication software such as HyperTerminal, enter **AT+CSQ** to check the received signal strength. The response returned will follow the format **+CSQ: <rss>, <ber>**

where: <rss> = received signal strength indication, and <ber> = channel bit error rate.

Refer to the table below for the description of the <rss> values returned.

Table 51. <rss> Value Description

<rss> Value	Description
0 – 10	Received signal strength is insufficient
11 – 31	Received signal strength is sufficient
32 – 98	Not defined
99	No measure available

9.3. Verifying the Network Registration

Using a communication software such as HyperTerminal, enter **AT+CREG?** to verify the network registration of the FX Series. Refer to the table below for the list of main responses returned.

Table 52. AT+CREG? Main Responses

AT+CREG? Response	Description
AT+CREG: 0, 0	Not registered
AT+CREG: 0, 1	Registered on the home network
AT+CREG: 0, 5	Registered on a roaming network

If the FX Series is not registered on the network, do the following:

- Check the connection between the FX Series and the antenna.
- Verify the signal strength to determine the received signal strength (Refer to section 9.2 Verifying the Received Signal Strength).

9.4. Checking the Band Selection

Using a communication software such as HyperTerminal, enter **AT+WMBS?** to check the band selection of the FX Series. Refer to the table below for the list of main responses returned.

Table 53. AT+WMBS? Main Responses

AT+WMBS? Response	Description
AT+WMBS: 0, x	Mono band mode 850MHz is selected
AT+WMBS: 1, x	Mono band mode extended 900MHz is selected
AT+WMBS: 2, x	Mono band mode 1800MHz is selected
AT+WMBS: 3, x	Mono band mode 1900MHz is selected

AT+WMBS? Response	Description
AT+WMBS: 4, x	Dual band mode 850/1900MHz is selected
AT+WMBS: 5, x	Dual band mode extended 900/1800MHz is selected
AT+WMBS: 6, x	Dual band mode extended 900/1900MHz is selected
AT+WMBS: 7, x	Quad-band mode 850/900E (extended)/1800/1900MHz is selected

Where:

When x = 0, the band has not been modified since the last boot of the FX Series;

When x = 1, the band has been modified since the last boot of the FX Series, and will have to be reset in order to take any previous modification(s) into account.

Enter **AT+WUBS?** to check the UMTS-FDD band selection of the FX100.

Table 54. AT+WUBS? Main Responses

AT+WUBS? Response	Description
AT+WUBS: y, x	<p>Where:</p> <ul style="list-style-type: none"> y = Band frequency configuration (bit field) in HEX format. Refer to document [2] AirPrime SL808xT and Q2698 Open AT Framework Commands Interface Guide for more information about this parameter. x = Reset flag (0 means the band(s) have not been modified since the last boot of the FX100, and 1 means the band(s) have been modified since the last boot and that the FX100 will have to be reset in order to take any previous modification(s) into account.

Enter **AT+WWSM?** to check the existing cellular network status of the FX100. Refer to the table below for the list of main responses returned.

Table 55. AT+WWSM? Main Responses

AT+WWSM? Response	Description
AT+WWSM: 0	GSM digital cellular system (GERAN)
AT+WWSM: 1	Universal Terrestrial Radio Access Network (UTRAN) only
AT+WWSM: 2, x	<p>3GPP systems (both GERAN and UTRAN)</p> <p>Where if x is:</p> <ul style="list-style-type: none"> 0 = automatic 1 = GERAN preferred 2 = UTRAN preferred

9.5. Switching Bands

Use the **AT+WMBS** AT Command to change the band setting of the FX Series and switch between EU and US bands and vice versa. Refer to the following table for the list of **AT+WMBS** parameters that can be used and their corresponding description.

Table 56. AT+WMBS Band Selection

AT+WMBS Command	Description
AT+WMBS=0,x	Switch to mono band mode 850MHz
AT+WMBS=1,x	Switch to mono band mode extended 900MHz
AT+WMBS=2,x	Switch to mono band mode 1800MHz
AT+WMBS=3,x	Switch to mono band mode 1900MHz
AT+WMBS=4,x	Switch to dual band mode 850/1900MHz
AT+WMBS=5,x	Switch to dual band mode extended 900/1800MHz
AT+WMBS=6,x	Switch to dual band mode extended 900/1900MHz
AT+WMBS=7,x	Switch to quad band mode 850/900E (extended)/1800/1900MHz

Where:

When x = 0, the FX Series will have to be reset to start on the specified band(s);

When x = 1, the band switch is effective immediately. However, this mode is forbidden while in Communication mode and during the FX Series' initialization.

Use **AT+WUBS** to change the UMTS-FDD band setting of the FX100.

Table 57. AT+WUBS Band Selection

AT+WUBS Command	Description
AT+WUBS=y, x	<p>Where:</p> <ul style="list-style-type: none"> y = Band frequency configuration (bit field) in HEX format. x = Optional reset parameter (0 means the FX100 will have to be reset to start on the specified band(s), and 1 means the band switch is effective immediately. Note that x=1 is forbidden while in Communication mode and during the FX100's initialization. <p>Refer to document [2] AirPrime SL808xT and Q2698 Open AT Framework Commands Interface Guide for more information about the parameters of this command.</p>

Use **AT+WWSM** to change the cellular network setting of the FX100. Refer to the table below for the list of main responses returned.

Table 58. AT+WWSM Cellular Network Setting

AT+WWSM Command	Description
AT+WWSM=0	GSM Digital Cellular System (GERAN)
AT+WWSM=1	Universal Terrestrial Radio Access Network (UTRAN) only
AT+WWSM=2,0	3GPP systems (both GERAN and UTRAN); automatic network
AT+WWSM=2,1	3GPP systems (both GERAN and UTRAN); GERAN preferred
AT+WWSM=2,2	3GPP systems (both GERAN and UTRAN); UTRAN preferred

9.6. Checking the PIN Code Status

Using a communication software such as HyperTerminal, enter **AT+CPIN?** to check the PIN code status. Refer to the table below for the list of main responses returned.

Table 59. AT+CPIN Main Responses

AT+CPIN Response	Description
+CPIN: READY	The PIN code has been entered.
+CPIN: SIM PIN	The PIN code has not been entered.

9.7. Echo Function

If no echo is displayed when entering an AT Command, it could mean either of the following:

- The “local echo” parameter of your communication software (HyperTerminal) is disabled.
- The FX Series echo function is disabled.

To enable the FX Series’ echo function, enter the AT Command **ATE1**.

When sending AT Commands to the FX Series using a communication software such as HyperTerminal, it is recommended to:

- Disable the “local echo” parameter of your communication software.
- Enable the FX Series’ echo function (use the **ATE1** command).

In a machine-to-machine communication with the FX Series, it is recommended to disable the FX Series’ echo function (using the **ATE0** AT command) in order to avoid useless embedded module processing.

9.8. Enabling/Disabling the Flash LED

The FX Series has a red LED indicator that shows the status of the GSM network. It is possible to disable this LED during Sleep mode in order to reduce power consumption. Using a communication software such as HyperTerminal, enter:

- **AT+WHCF=1,0** to deactivate Flash LED
- **AT+WHCF=1,1** to activate Flash LED

Note: You will need to restart the FX Series for the new setting to take effect.

9.9. Firmware Upgrade Procedure

The firmware upgrade procedure is used to update the firmware embedded in the FX Series. This procedure consists of downloading the firmware into internal memories through the RS232 serial link available on the 15-pin SUB-D serial connector.

Refer to document [8] Firmware Upgrade Procedure document for more information regarding this procedure.

9.10. Main AT Commands for the FX Series

The table below lists the main AT Commands required for starting the FX Series. For other available AT Commands, refer to documents [1] Open AT Application Framework AT Commands Interface Guide and [2] AirPrime SL808xT and Q2698 Open AT Framework Commands Interface Guide.

Table 60. Main AT Commands used for the FX Series

Feature/Function	AT Command	Response	Description
Check network registration	AT+CREG?	+CREG: 0,1	The FX Series is registered on the network.
		+CREG: 0,2	The FX Series is not registered on the network; registration attempt is ongoing.
		+CREG: 0,0	The FX Series is not registered on the network; no registration attempt has been made.
Enter PIN code	AT+CPIN=xxxx (xxxx = PIN code)	OK	PIN code accepted.
		+CME ERROR: 16	Incorrect PIN code (with +CMEE = 1 mode*).
		+CME ERROR: 3	PIN code already entered (with +CMEE = 1 mode*).
Check the selected band	AT+WMBS?	+WMBS: <Band>,<ResetFlag> OK	The currently selected band mode is returned.
Switch bands	AT+WMBS=<Band>	OK	Band switch is accepted; the FX Series has to be reset for the change to be effective.
	AT+WMBS=<Band>,0	OK	Band switch is accepted; the FX Series has to be reset for the change to be effective.
	AT+WMBS=<Band>,1	OK	Band switch is accepted and the GSMS stack has been restarted.
	AT+WMBS=<Band>	+CME ERROR: 3	Band selected is not allowed.
Receive a call	ATA	OK	Answer the call.
Initiate a call	ATD<phone number>; (Do not forget the « ; » at the end for « voice » call)	OK	Communication established.
		+CME ERROR: 11	PIN code not entered (with +CMEE = 1 mode).
		+CME ERROR: 3	AOC credit exceeded or communications is already established.
Initiate an emergency call	ATD112; (Do not forget the « ; » at the end for « voice » call)	OK	Communications established.
Hang up	ATH	OK	
Communication has been loss		NO CARRIER	
Store the parameters in EEPROM	AT&W	OK	The configuration settings are stored in EEPROM (non-volatile memory).

* The command AT+CMEE=1 switches to a mode that enables a more complete error diagnostic.

10. Troubleshooting the FX Series

This section of the document describes possible problems that might be encountered when using the FX Series and their corresponding solutions.

To read about other troubleshooting information, refer to the Knowledge Base page at <http://www.sierrawireless.com/en/Support/knowledgebase.aspx>.

10.1. No Communications with the FX Series through the Serial Link

If the FX Series does not answer to AT commands through the serial link, refer to the table below for possible causes and their corresponding solutions.

Table 61. No Communications with the FX Series Through the Serial Link

If the FX Series returns	Then ask	Action
Nothing	Is the FX Series powered correctly?	Make sure that the external power supply is connected to the FX Series and provides a voltage within the range of 4.75V to 32V.
	Is the serial cable connected at both sides?	Check the serial cable connection.
	Does the serial cable correctly follow the pin assignments? Refer to section 5.1.2 Serial Interface for more information about the serial cable pin assignments.	Connect the cable by following the pin assignments as given in Table 13 Serial Connector Pin Description.
Nothing or non-significant characters	Is the communication program properly configured on the PC?	Ensure that the settings of the communication program are compatible with the settings of the FX Series. The FX Series factory settings are: <ul style="list-style-type: none"> • Data bits = 8 • Parity = none • Stop bits = 1 • Baud = 115200 bps • Flow control = hardware
	Is there another program interfering with the communication program (i.e. conflict on communication port access)?	Close the interfering program.

10.2. Receiving “ERROR”

The FX Series returns an “ERROR” message (in reply to an AT command) in the following cases:

- The AT command syntax is incorrect. In this case, check the command syntax (refer to documents [1] Open AT Application Framework AT Commands Interface Guide and [2] AirPrime SL808xT and Q2698 Open AT Framework Commands Interface Guide for more information).
- The AT command syntax is correct, but was transmitted using the wrong parameters

Enable the verbose error report method to see the error codes associated with the command syntax.

- Enter the **AT+CMEE=1** command in order to change the error report method to the verbose method, which includes the error codes.
- Re-enter the AT command which previously caused the reception of an “ERROR” message in order to get the Mobile Equipment error code.

When the verbose error report method is enabled, the response of the FX Series in case of error is either:

- +CME ERROR: <error result code>
- or
- +CMS ERROR: <error result code>

Refer to documents [1] Open AT Application Framework AT Commands Interface Guide and [2] AirPrime SL808xT and Q2698 Open AT Framework Commands Interface Guide for more information on the error result code description and further details on the **AT+CMEE** command.

Caution: *It is strongly recommended to always enable the verbose error report method to get the Mobile Equipment error code (enter the **AT+CMEE=1** command).*

10.3. Receiving “NO CARRIER”

If the FX Series returns a “NO CARRIER” message upon an attempted call (voice or data), refer to the following table for possible causes and their corresponding solutions.

Table 62. Receiving a “No Carrier” Message

If the FX Series returns	Then ask	Action
“NO CARRIER”	Is the received signal strong enough?	Refer to section 9.2 Verifying the Received Signal Strength to verify the strength of the received signal.
	Is the FX Series registered on the network?	Refer to section 9.3 Verifying the Network Registration to verify the network registration.
	Is the antenna properly connected?	Refer to section 5.2.2.2 Antenna Specifications for more information about the FX Series’ antenna requirements.
	Is the band selection correct?	Refer to section 9.5 Switching Bands for more information about switching between bands.
“NO CARRIER” (when trying to issue a voice communication)	Is the semicolon (;) entered immediately after the phone number in the AT command?	Ensure that the semicolon (;) is entered immediately after the phone number in the AT command. e.g. ATD#####;

If the FX Series returns	Then ask	Action
"NO CARRIER" (when trying to issue a data communication)	Is the SIM card configured for data/fax calls?	Configure the SIM card for data/fax calls. (Ask your network provider if necessary).
	Is the selected bearer type supported by the called party?	Ensure that the selected bearer type is supported by the called party.
	Is the selected bearer type supported by the network?	Ensure that the selected bearer type is supported by the network. If still unsuccessful, try selecting the bearer type using the AT command: AT+CBST=0,0,3

If the FX Series returns a "NO CARRIER" message, you may retrieve the extended error code by using the AT Command **AT+CEER**. Refer to the following table for the interpretation of extended error codes.

Table 63. Extended Error Codes

Error Code	Diagnosis	Hint
1	Unallocated phone number	
16	Normal call clearing	
17	User busy	
18	No user responding	
19	User alerting, no answer	
21	Call rejected	
22	Number changed	
31	Normal, unspecified	
50	Requested facility not subscribed	Check your subscription. (Is data subscription available?)
68	ACM equal or greater than ACMmax	The credit of your pre-paid SIM card has expired.
252	Call barring on outgoing calls	
253	Call barring on incoming calls	
3, 6, 8, 29, 34, 38, 41, 42, 43, 44, 47, 49, 57, 58, 63, 65, 69, 70, 79, 254	Network causes	Refer to documents [1] Open AT Application Framework AT Commands Interface Guide and [2] AirPrime SL808xT and Q2698 Open AT Framework Commands Interface Guide for further details or call your network provider.

For all other codes and/or details, refer to the documents listed in section 17.1 Firmware Documentation.



11. Power Consumption

The following sub-sections details out the power consumption values of the FX Series for various modes and RF bands. These consumption values were obtained by performing measurements on FX Series samples at a temperature of 25°C using a 3V SIM card.

Note: For FXT009 power consumption, the software version used is R7.43.

For FX100 power consumption, the software version used is R7.50 A1.

Refer to document [8] Firmware Upgrade Procedure for details on how to upgrade FX Series firmware.

The table below gives the average power consumption of the FX Series for the first 10s when power supply (DC-IN, supplied by Agilent 66321D in this example) is initially applied to it with no serial port, LED ON or SIM card at ambient temperature.

Table 64. Initial Power Consumption (Typical)

Configuration	FXT009 Average Power Consumption with FW R7.43	FX100 Average Power Consumption with FW R7.50 A1
DC-IN @ 13.2V	20.5mA	18mA

11.1. Various Operating Modes

The power consumption levels of the FX Series vary depending on the operating mode used. Refer to the table below for the different kinds of operating modes available. Refer to Appendix 3.1 of documents [1] Open AT Application Framework AT Commands Interface Guide and [2] AirPrime SL808xT and Q2698 Open AT Framework Commands Interface Guide for the working mode description.

Table 65. FX Series Operating Modes

Operating Mode	Description
GSM Connected Mode	The FX Series is connected to a live GSM network, during circuit switch voice or data call.
Transfer Mode	The FX Series has GPRS data transfer connection with a live network, during packet data transmission.
Active mode with GSM stack in Idle	When the RF function is active and the FX Series is synchronized with the network, but there is currently no communication.
Sleep mode with GSM stack in Idle	When the RF function is disabled but is regularly activated to remain synchronized with the network. This mode only works when the DTE sends an AT command to shut the serial link down (DTE turns DTR to inactive state).
Active Mode	When the RF function is disabled and there is no synchronization with the network but the UART is available.
Sleep Mode	When the RF function is disabled, and there is no synchronization with the network and the UART is not available.

Operating Mode	Description
Alarm Mode	<p>Low power consumption mode, the only feature which is available in this mode is the alarm wake up.</p> <p>When the alarm clock is set for the FX Series with ALL of the following conditions:</p> <ul style="list-style-type: none"> • before the alarm time is up • with the ON/OFF signal pulled to GND • with AT+CPOF entered from a computer that is connected to the FX Series
Serial Port Auto Shut Down Feature	<p>The serial link can be shut down when there is no activity between the DTE and the FX Series.</p> <p>This auto shut down feature can be enabled by AT command. Refer to section 5.1.2.4 Serial Port Auto Shut Down Feature for more information on this feature.</p>
FLASH LED Activated/Deactivated	<p>The FX Series Flash LED can be enabled or disabled by AT command. Refer to section 9.8 Enabling/Disabling the Flash LED for more information on this feature.</p>

11.2. Working Mode Features

The table below sums up the feature availability in each mode.

Table 66. FX Series Operating Modes Feature Availability

Features	Alarm Mode	ACTIVE Mode with GSM Stack in Idle	SLEEP Mode with GSM Stack in Idle	ACTIVE Mode	SLEEP Mode	Connected Mode	Transfer Mode
Alarm	✓	✓	✓	✓	✓	✓	✓
Wake-up Open AT Application Framework on timer events	-	✓	✓	✓	✓	✓	✓
GSM/GPRS paging (alert from the network for incoming call, incoming SMS or incoming GPRS data)	-	✓	✓	-	-	✓	✓
SIM	-	✓	-	-	-	✓	✓
UARTs	-	✓	-	✓	-	✓	✓
USB	-	✓	-	✓	-	✓	✓
SPIs	-	✓	-	✓	-	✓	✓
I ² C	-	✓	-	✓	-	✓	✓
GPIO	-	✓	-	✓	-	✓	✓
ADCs	-	✓	-	✓	-	✓	✓
Buzzer	-	✓	-	✓	-	✓	✓
Keypad	-	✓	✓	✓	✓	✓	✓
External IT	-	✓	✓	✓	✓	✓	✓
Flash LED	-	✓	✓	✓	✓	✓	✓

11.3. Connected Mode Power Consumption

Table 67. Power Consumption of FXT009 in Connected Mode with Serial Port ON and Flash LED Activated (typical values)

Mode	Parameters		I _{average}			I _{peak}		Unit
			DC-IN =4.75V	DC-IN =13.2V	DC-IN =32V	DC-IN =4.75V	DC-IN =13.2V	
GSM	850 MHz	PCL5 (TX power 33dBm)	311	100	43	2465	1193	mA
		PCL19 (TX power 5dBm)	132	47	21	400	127	mA
	900 MHz	PCL5 (TX power 33dBm)	319	102	44	2655	1222	mA
		PCL19 (TX power 5dBm)	136	48	21	411	130	mA
	1800 MHz	PCL0 (TX power 30dBm)	245	82	36	1612	1068	mA
		PCL15 (TX power 0dBm)	129	46	20	352	118	mA
1900 MHz	PCL0 (TX power 30dBm)	253	85	37	1915	1113	mA	
	PCL15 (TX power 0dBm)	129	46	20	358	116	mA	
GPRS class 8 (1TX, 4RX)	850 MHz	PCL5 (gamma 3)	297	95	42	2476	1208	mA
		PCL19 (gamma 17)	125	44	20	369	120	mA
	900 MHz	PCL5 (gamma 3)	304	97	42	2588	1222	mA
		PCL19 (gamma 17)	127	45	20	374	121	mA
	1800 MHz	PCL0 (gamma 3)	234	79	34	1560	1072	mA
		PCL15 (gamma 18)	123	44	19	325	108	mA
1900 MHz	PCL0 (gamma 3)	241	81	35	1773	1090	mA	
	PCL15 (gamma 18)	122	43	19	324	108	mA	
GPRS class 10 (2TX, 3RX)	850 MHz	PCL5 (gamma 3)	521	163	71	2503	1162	mA
		PCL19 (gamma 17)	167	59	24	384	125	mA
	900 MHz	PCL5 (gamma 3)	533	166	72	2725	1211	mA
		PCL19 (gamma 17)	169	60	26	389	127	mA
	1800 MHz	PCL0 (gamma 3)	389	129	56	1592	1092	mA
		PCL15 (gamma 18)	161	57	25	337	1115	mA
1900 MHz	PCL0 (gamma 3)	406	134	58	1836	1136	mA	
	PCL15 (gamma 18)	160	57	25	338	115	mA	
EGPRS class 8 (1TX, 4RX)	850 MHz	PCL8 (gamma 6)	276	93	41	1796	1087	mA
		PCL19 (gamma 17)	183	65	28	648	198	mA
	900 MHz	PCL8 (gamma 6)	281	95	41	2032	1108	mA
		PCL19 (gamma 17)	184	65	28	653	199	mA
	1800 MHz	PCL2 (gamma 5)	243	84	36	1563	1052	mA
		PCL15 (gamma 18)	175	62	27	563	173	mA
1900 MHz	PCL2 (gamma 5)	250	86	37	1442	1024	mA	
	PCL15 (gamma 18)	176	62	27	565	175	mA	

Mode	Parameters		I _{average}			I _{peak}		Unit
			DC-IN =4.75V	DC-IN =13.2V	DC-IN =32V	DC-IN =4.75V	DC-IN =13.2V	
EGPRS class 10 (2TX, 3RX)	850 MHz	PCL8 (gamma 6)	435	143	62	1806	1102	mA
		PCL19 (gamma 17)	243	86	37	649	201	mA
	900 MHz	PCL8 (gamma 6)	445	146	63	2016	1126	mA
		PCL19 (gamma 17)	245	86	37	649	201	mA
	1800 MHz	PCL2 (gamma 5)	367	124	54	1436	1052	mA
		PCL15 (gamma 18)	228	81	35	566	175	mA
	1900 MHz	PCL2 (gamma 5)	380	128	56	1480	1076	mA
		PCL15 (gamma 18)	229	81	35	563	176	mA

Table 68. Power Consumption of FX100 in Connected Mode with Serial Port OFF, Flash LED OFF and USB ON (typical values)

Mode	Parameters		I _{average}			I _{peak}		Unit
			DC-IN =4.75V	DC-IN =13.2V	DC-IN =32V	DC-IN =4.75V	DC-IN =13.2V	
GSM	850 MHz	PCL5 (TX power 33dBm)	420	107	46	3625	703	mA
		PCL19 (TX power 5dBm)	97	34	15	682	249	mA
	900 MHz	PCL5 (TX power 33dBm)	428	109	47	3782	710	mA
		PCL19 (TX power 5dBm)	99	35	15	698	215	mA
	1800 MHz	PCL0 (TX power 30dBm)	299	91	39	2374	536	mA
		PCL15 (TX power 0dBm)	101	35	16	728	226	mA
	1900 MHz	PCL0 (TX power 30dBm)	269	86	37	2169	497	mA
		PCL15 (TX power 0dBm)	102	36	16	813	255	mA
GPRS class 8 (1TX, 4RX)	850 MHz	PCL5 (gamma 3)	363	102	45	3478	702	mA
	900 MHz	PCL5 (gamma 3)	384	107	42	3600	720	mA
	1800 MHz	PCL0 (gamma 3)	291	84	38	2413	538	mA
	1900 MHz	PCL0 (gamma 3)	253	83	36	2008	486	mA
GPRS class 10 (2TX, 3RX)	850 MHz	PCL5 (gamma 3)	654	174	76	3503	880	mA
	900 MHz	PCL5 (gamma 3)	698	185	78	3489	1001	mA
	1800 MHz	PCL0 (gamma 3)	476	143	61	2348	910	mA
	1900 MHz	PCL0 (gamma 3)	459	129	58	2201	833	mA
GPRS class 12 (4TX, 1 RX)	850 MHz	PCL5 (gamma 3)	467	147	72	1414	749	mA
	900 MHz	PCL5 (gamma 3)	519	180	75	1510	787	mA
	1800 MHz	PCL0 (gamma 3)	553	184	78	1587	794	mA
	1900 MHz	PCL0 (gamma 3)	570	183	76	1598	801	mA
EGPRS class 8 (1TX, 4RX)	850 MHz	PCL8 (gamma 6)	197	67	58	1508	401	mA
	900 MHz	PCL8 (gamma 6)	203	66	29	1464	406	mA
	1800 MHz	PCL2 (gamma 5)	192	68	29	1404	497	mA
	1900 MHz	PCL2 (gamma 5)	193	64	28	1357	387	mA

Mode	Parameters		I _{average}			I _{peak}		Unit
			DC-IN =4.75V	DC-IN =13.2V	DC-IN =32V	DC-IN =4.75V	DC-IN =13.2V	
EGPRS class 10 (2TX, 3RX)	850 MHz	PCL8 (gamma 6)	312	100	42	1453	740	mA
	900 MHz	PCL8 (gamma 6)	301	95	43	1470	772	mA
	1800 MHz	PCL2 (gamma 5)	313	108	49	1521	775	mA
	1900 MHz	PCL2 (gamma 5)	293	97	43	1454	785	mA
EGPRS class 12 (4TX, 1RX)	850 MHz	PCL8 (gamma 6)	437	150	66	1441	718	mA
	900 MHz	PCL8 (gamma 6)	459	164	70	1460	804	mA
	1800 MHz	PCL2 (gamma 5)	567	185	78	1557	811	mA
	1900 MHz	PCL2 (gamma 5)	507	174	72	1494	765	mA
UMTS (Voice)	Band I	+22 dBm	637	222	94	1090	767	mA
		+10 dBm	227	81	34	1057	442	mA
	Band II	+22 dBm	616	210	88	1074	830	mA
		+10 dBm	232	80	35	1062	423	mA
	Band V	+22 dBm	606	204	89	1042	898	mA
		+10 dBm	204	70	31	842	417	mA
	Band VI	+22 dBm	609	204	88	1036	858	mA
		+10 dBm	200	71	30	978	404	mA
Band VIII	+22 dBm	582	200	87	1050	895	mA	
	+10 dBm	328	114	51	804	646	mA	
UMTS (Data Transfer 2) 384 kbit/s	Band I	+22 dBm	694	225	97	585	781	mA
		+10 dBm	243	85	42	987	457	mA
	Band II	+22 dBm	798	226	107	1306	899	mA
		+10 dBm	250	89	38	1121	481	mA
	Band V	+22 dBm	628	208	90	1095	961	mA
		+10 dBm	206	73	33	1117	430	mA
	Band VI	+22 dBm	669	221	92	1133	827	mA
		+10 dBm	216	76	32	1170	406	mA
Band VIII	+22 dBm	594	201	87	1045	1003	mA	
	+10 dBm	330	118	52	810	708	mA	
HSDPA Data Transfer 2 Cat.10 14.4 Mbit/s	Band I	+22 dBm	736	243	103	1155	754	mA
		+10 dBm	314	109	48	747	592	mA
	Band II	+22 dBm	636	213	96	1032	724	mA
		+10 dBm	322	107	46	703	585	mA
	Band V	+22 dBm	664	225	96	1024	863	mA
		+10 dBm	278	98	42	774	509	mA
	Band VI	+22 dBm	705	227	95	885	928	mA
		+10 dBm	269	92	42	668	415	mA
Band VIII	+22 dBm	668	219	91	988	656	mA	
	+10 dBm	386	133	61	820	749	mA	

Mode	Parameters		I_{average}			I_{peak}		Unit
			DC-IN =4.75V	DC-IN =13.2V	DC-IN =32V	DC-IN =4.75V	DC-IN =13.2V	
HSUPA Data Transfer 2 Cat.5 2 Mbit/s	Band I	+22 dBm	697	238	91	960	509	mA
		+10 dBm	377	130	58	659	519	mA
	Band II	+22 dBm	635	217	85	899	498	mA
		+10 dBm	483	132	58	786	534	mA
	Band V	+22 dBm	660	226	87	951	499	mA
		+10 dBm	347	120	54	625	514	mA
	Band VI	+22 dBm	657	224	88	922	549	mA
		+10 dBm	335	117	52	618	506	mA
Band VIII	+22 dBm	638	220	85	946	557	mA	
	+10 dBm	401	140	54	715	558	mA	

11.4. Non-Connected Mode Power Consumption

Note: The USB port must be deactivated to enter Sleep Mode.

Table 69. Power Consumption of FXT009 in Non-Connected Mode (typical values)

Mode	Serial Port Status	I_{average}			Unit
		DC-IN=4.75V	DC-IN=13.2V	DC-IN=32V	
Active Mode	ON	80.3	28.4	12.5	mA
Sleep Mode, Flash LED activated	ON	34.6	12.2	5.6	mA
	OFF	5.3	2.1	1.2	mA
Sleep Mode, Flash LED deactivated	ON	29.8	10.8	5	mA
	OFF	1.3	0.6	0.5	mA
Active Idle Mode, page 9	ON	53.6	18.7	8.5	mA
	OFF	23.5	8.5	4.1	mA
Sleep Idle Mode, page 9	ON	28.6	10.4	5	mA
	OFF	4.7	1.9	1.2	mA
Alarm Mode	OFF	0.4	0.4	0.4	mA

Table 70. Power Consumption of FX100 in Non-Connected Mode with UART ON, FLASH LED OFF and USB OFF (typical values)

Mode	Serial Port Status	I _{average}			Unit
		DC-IN=4.75V	DC-IN=13.2V	DC-IN=32V	
Active Idle Mode, HSPA	ON	45.82	16.56	7.6	mA
	OFF	15.48	5.96	2.81	mA
Sleep Idle Mode, HSPA	ON	32.66	11.89	5.8	mA
	OFF	3.09	1.39	0.78	mA
Active Idle Mode, 2G page 9	ON	46.01	16.47	7.5	mA
	OFF	16.43	6.01	2.96	mA
Sleep Idle Mode, 2G page 9	ON	31.91	11.51	5.65	mA
	OFF	2.7	1.12	0.81	mA
Active Idle Mode, 2G page 2	ON	47.11	16.82	7.75	mA
	OFF	17.54	6.4	3.15	mA
Sleep Idle Mode, 2G page 2	ON	33.51	12.07	5.65	mA
	OFF	4.3	1.64	1.14	mA
Alarm Mode	OFF	2.7	1.23	0.91	mA

11.5. Consumption Measurement Procedure

This chapter describes the procedure for consumption measurement which is used to obtain the FX Series consumption specifications.

The FX Series consumption specification values are measured for all operating modes available. For more information about switching between the operating modes, refer to the appendix of documents [1] Open AT Application Framework AT Commands Interface Guide and [2] AirPrime SL808xT and Q2698 Open AT Framework Commands Interface Guide.

Consumption results are highly dependent on the hardware configuration used during measurement and the following chapter describes the hardware configuration settings that should be used to obtain optimum consumption measurements.

11.5.1. Hardware Configuration

The following hardware configuration includes both the measurement equipment and the FX Series.

11.5.1.1. Equipment

Three devices are used to perform consumption measurement:

- A communication tester
- A current measuring power supply
- A computer, to control the FX Series and to save measurement data

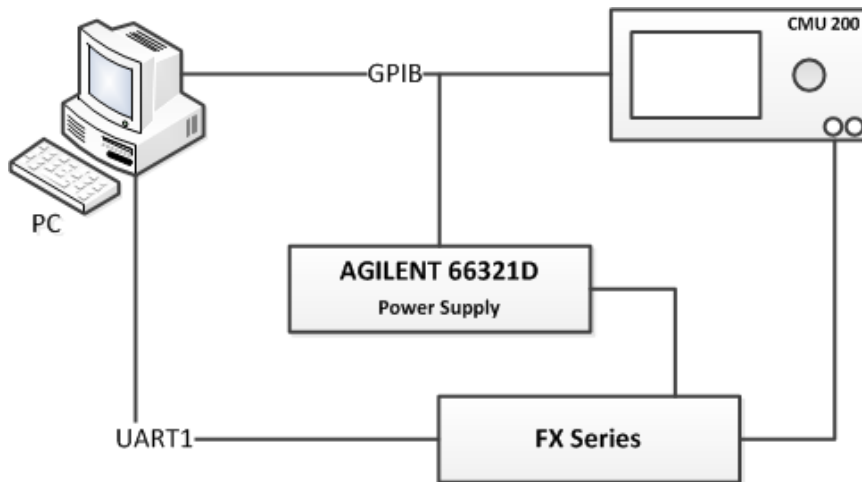

Figure 40. Typical Hardware Configuration for Power Consumption Measurement

The communication tester is a **CMU 200** from **Rhode & Schwartz**. This tester offers all required GSM/GPRS/EGPRS/CDMA/WCDMA network configurations and allows a wide range of network configurations to be set.

The **66321D** power supply is used to supply the FX Series, and it could also be used to measure the total current drain by the device. The current measurement data is read through the GPIB connection. **Rhode & Schwartz NGSM 32/10** is used when measuring with 32V input voltage.

Note that a SIM card must be inserted during all consumption measurements.

The following table lists the recommended equipments to use for the consumption measurement.

Table 71. List of Recommended Equipments

Device	Manufacturer	Part Number	Notes/Description
Communication Tester	Rhode & Schwartz	CMU 200	Quad Band GSM/DCS/GPRS/EGPRS/CDMA/ WCDMA
Current measuring power supply	Agilent	66321D	Used for DC-IN

11.5.1.2. SIM Cards Used

Consumption measurement may be performed with either 3-Volt or 1.8-Volt SIM cards. However, all specified consumption values are for a 3-Volt SIM card.

Caution: *The SIM card's voltage is supplied by the FX Series power supply. Consumption measurement results may vary depending on the SIM card.*

11.5.2. Software Configuration

This section defines the software configuration for the equipment(s) used and the FX Series settings.

11.5.2.1. FX Series Configuration

The FX Series software configuration is performed by selecting the operating mode to use in performing the measurement.

A description of the operating modes and the procedures used to change operating modes are given in the appendix of documents [1] Open AT Application Framework AT Commands Interface Guide and [2] AirPrime SL808xT and Q2698 Open AT Framework Commands Interface Guide.

Refer to the following list for the available operating modes of the FX Series:

- Active Idle Mode
- Sleep Idle Mode
- Active Mode
- Sleep Mode
- Connected Mode
- Transfer Mode class 8 (4Rx/1Tx) (in GPRS mode)
- Transfer Mode class 10 (3Rx/2Tx) (in GPRS mode)
- Transfer Mode class 12 (1Rx/4Tx) (in GPRS mode) – for FX100 only
- Transfer Mode class 8 (4Rx/1Tx) (in EDGE mode)
- Transfer Mode class 10 (3Rx/2Tx) (in EDGE mode)
- Transfer Mode class 12 (1Rx/4Tx) (in EDGE mode) – for FX100 only
- Connected Mode (in UMTS mode) – for FX100 only
- Data Transfer (in UMTS mode and HSxPA mode) – for FX100 only

Note: The USB port must be deactivated to enter Sleep Mode.

11.5.2.2. Equipment Configuration

The communication tester is set according to the FX Series operating mode. Paging during idle modes, Tx burst power, RF band and GSM/DCS/GPRS may be selected on the communication tester.

Refer to the following table for the network analyzer configuration according to operating mode.

Table 72. Operating Mode Information

Operating Mode	Communication Tester Configuration	
Alarm Mode	N/A	
Active Mode with GSM stack in Idle	Paging 9 (Rx burst occurrence ~2s)	
	Paging 2 (Rx burst occurrence ~0,5s)	
Sleep Mode with GSM stack in Idle	Paging 9 (Rx burst occurrence ~2s)	
	Paging 2 (Rx burst occurrence ~0,5s)	
Active Mode	N/A	
Sleep Mode	N/A	
Connected Mode	850/900 MHz	PCL5 (TX power 33dBm)
		PCL19 (TX power 5dBm)
	1800/1900 MHz	PCL0 (TX power 30dBm)
		PCL15 (TX power 0dBm)

Operating Mode		Communication Tester Configuration	
GPRS	Transfer Mode class 8 (4Rx/1Tx)	850/900 MHz	Gam.3 (TX power 33dBm)
			Gam.17 (TX power 5dBm)
		1800/1900 MHz	Gam.3 (TX power 30dBm)
			Gam.18 (TX power 0dBm)
	Transfer Mode class 10 (3Rx/2Tx)	850/900 MHz	Gam.3 (TX power 33dBm)
			Gam.17 (TX power 5dBm)
		1800/1900 MHz	Gam.3 (TX power 30dBm)
			Gam.18 (TX power 0dBm)
	Transfer Mode class 12 (1Rx/4Tx)	850/900 MHz	Gam.3 (TX power 33dBm)
			Gam.17 (TX power 5dBm)
		1800/1900 MHz	Gam.3 (TX power 30dBm)
			Gam.18 (TX power 0dBm)
EGPRS	Transfer Mode class 2 (1Rx/1Tx)	850/900 MHz	Gam.6 (TX power 27dBm)
			Gam.17 (TX power 5dBm)
		1800/1900 MHz	Gam.5 (TX power 26dBm)
			Gam.18 (TX power 0dBm)
	Transfer Mode class 10 (3Rx/2Tx)	850/900 MHz	Gam.6 (TX power 27dBm)
			Gam.17 (TX power 5dBm)
		1800/1900 MHz	Gam.5 (TX power 26dBm)
			Gam.18 (TX power 0dBm)
	Transfer Mode class 12 (1Rx/4Tx)	850/900 MHz	Gam.6 (TX power 27dBm)
			Gam.17 (TX power 5dBm)
		1800/1900 MHz	Gam.5 (TX power 26dBm)
			Gam.18 (TX power 0dBm)
UMTS Connected Mode (VOICE)	UMTS 2100 (BAND I)		+22dBm
			+10dBm
	UMTS 1900 (BAND II)		+22dBm
			+10dBm
	UMTS 850 (BAND V)		+22dBm
			+10dBm
	UMTS 800 (BAND VI)		+22dBm
			+10dBm
	UMTS 900 (BAND VIII)		+22dBm
			+10dBm
UMTS (Data Transfer) 384kbit/s	UMTS 2100 (BAND I)		+22dBm
			+10dBm
	UMTS 1900 (BAND II)		+22dBm
			+10dBm
	UMTS 850 (BAND V)		+22dBm
			+10dBm
	UMTS 800 (BAND VI)		+22dBm
			+10dBm
	UMTS 900 (BAND VIII)		+22dBm
			+10dBm

Operating Mode	Communication Tester Configuration	
HSDPA Data Transfer Cat.8 7.2Mbit/s	UMTS 2100 (BAND I)	+22dBm
		+10dBm
	UMTS 1900 (BAND II)	+22dBm
		+10dBm
	UMTS 850 (BAND V)	+22dBm
		+10dBm
	UMTS 800 (BAND VI)	+22dBm
		+10dBm
	UMTS 900 (BAND VIII)	+22dBm
		+10dBm
HSUPA Data Transfer CAT.5 2Mbit/s	UMTS 2100 (BAND I)	+22dBm
		+10dBm
	UMTS 1900 (BAND II)	+22dBm
		+10dBm
	UMTS 850 (BAND V)	+22dBm
		+10dBm
	UMTS 800 (BAND VI)	+22dBm
		+10dBm
	UMTS 900 (BAND VIII)	+22dBm
		+10dBm

12. Recommendations when Using the FX Series on Trucks

Caution: The power supply connection of the FX Series must **never** be directly connected to the truck battery.

12.1. Recommended Power Supply Connection on Trucks

All trucks have a circuit breaker on the exterior of the cabin. The circuit breaker is used for safety reasons: if a fire blazes in the trucks, (for example, on the wiring trunk) the driver may cut the current source to avoid any damage (explosion). The circuit breaker is connected to the truck ground, most often associated with the fuse box.

Most truck circuit breakers do not cut the Positive Supply line of the battery, but cut the ground line of the latter.

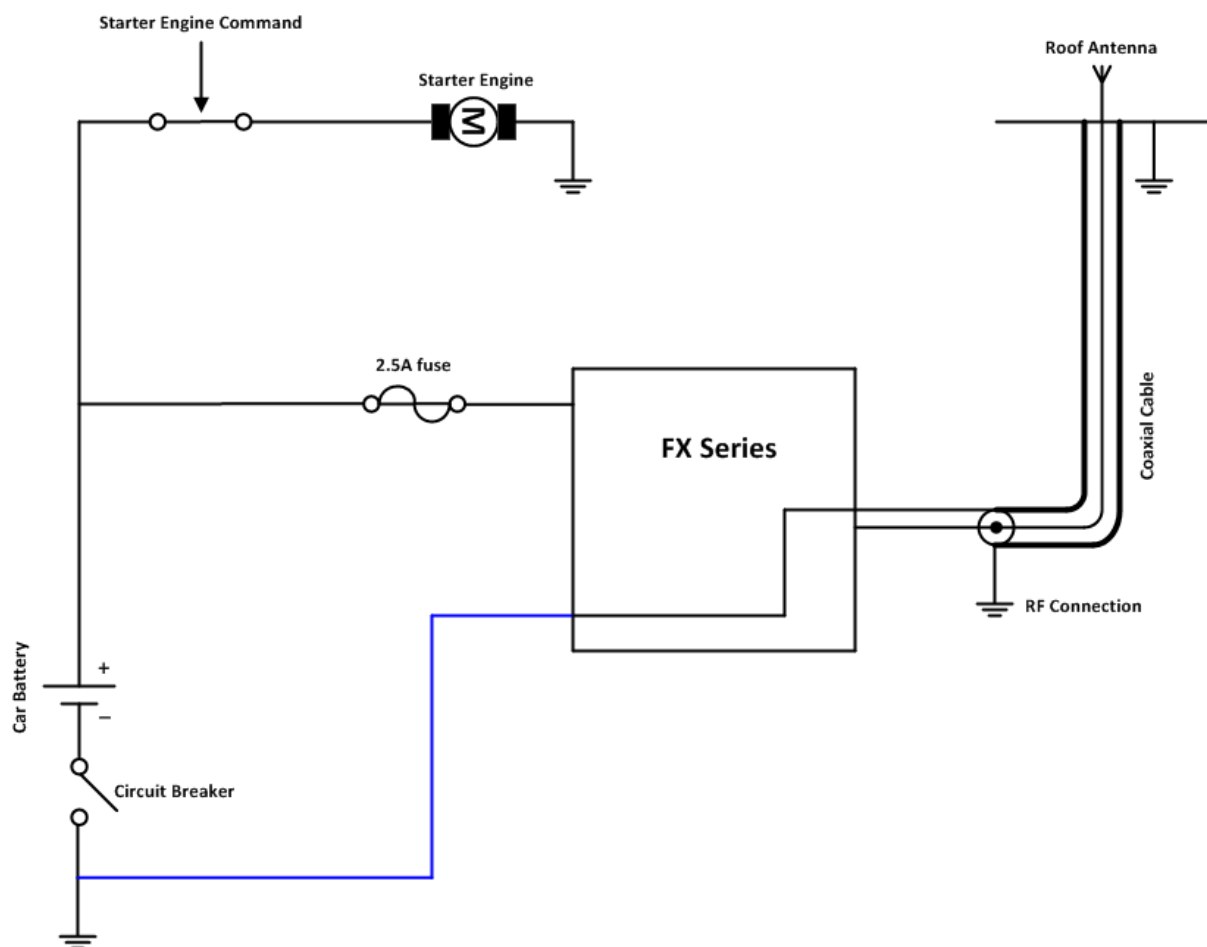

Figure 41. Recommended Power Supply Connection on Trucks

The figure above shows the recommended power supply connection where the ground connection of the FX Series is not directly connected to the battery but is connected after the Circuit Breaker (on the truck ground or the fuse box).

12.2. Technical Constraints on Trucks

It is highly recommended to directly connect the power supply on the circuit breaker rather than on the battery. The FX Series may be damaged when starting the truck if the circuit breaker is switched OFF (in this case, the truck ground and the battery ground will be connected through the FX Series as shown in the following figure).

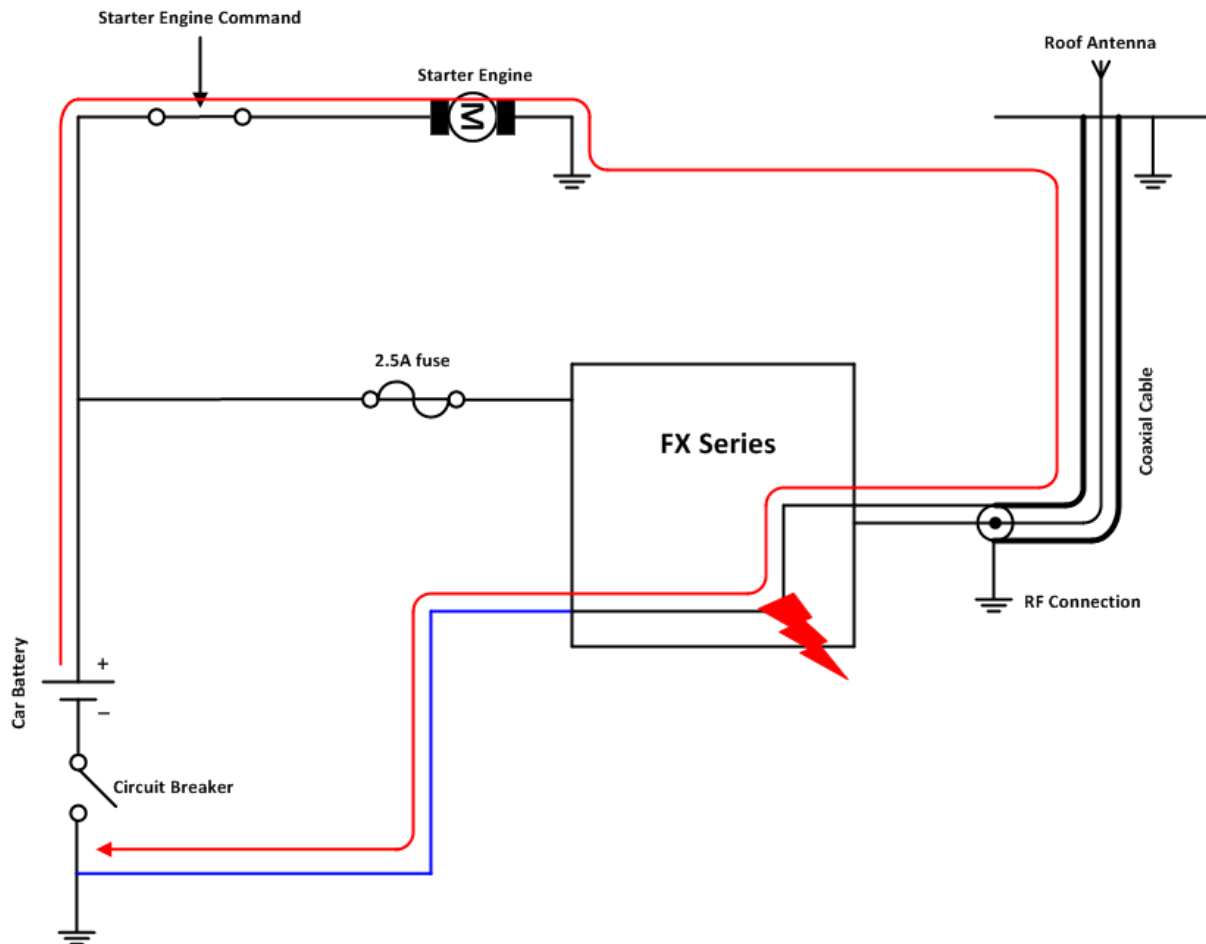

Figure 42. Example of an Electrical Connection That May Damage the FX Series

The figure above gives an example of an electrical connection which may dramatically damage the FX Series when its ground connection is directly connected to the battery ground.

In this example, when the circuit breaker is switched OFF, the current flows through the FX Series and powers the electrical circuit of the truck (for example, the dashboard). Furthermore, when the Starter Engine command is used, it will destroy the cables or the FX Series.

Since the internal tracks of the FX Series are not designed to support high currents (up to 60A when starting the truck), they will be destroyed.



13. FX Series Accessories

13.1. Standard Accessories

The FX Series has the following standard accessories:

- 6-wire cable accessory with IO (DC IN, GND, Vref, GPIO25/INT1, GPIO21 (GPIO35 for FX100), ON/OFF) Refer to the following table for the color-coding of the 6-wire cable accessory.
- USB Cable wire (for FXT009 bundle only)
- Mounting bridle

Table 73. 6-Wire Cable Accessory Color Coding

IO	Cable Accessory Color
DC-IN	RED
GND	BLACK
VREF	GREEN
GPIO21 (GPIO35 for FX100)	ORANGE
ON/OFF	YELLOW
GPIO25/INT1	BROWN

13.2. Additional Optional Accessories

- RS232 serial link cable
- AC/DC Power supply
- GSM, Diversity and GPS antennas
- FXTE02 Ethernet X-card (Refer to section 7 X-card for more information about the FXTE02.)

Note: The above items are ONLY considered as accessories of the FX Series. They are NOT considered as part of the FX Series.

13.3. Component Recommendations

The following tables list the recommended components/parts to use with the FX Series.

Table 74. List of Recommended Accessories

Component	Part/Reference Number	Supplier
Quad-band antenna	W1900	PULSE
Power adaptor	GS-2034 (RE) 25W (MAX) Out: 12V -2A In: 100 to 240V – 47/63 Hz – 550mA Mounted with micro-fit connector	GlobTeK
6-wire cable accessory + Fuse	Cable: K96975060049A FUSE: T2AL250V VDE Slow Break	Grand-TEK Technology
GPS antenna	GC-GAACZ-A55	GIGA-Concept
Ethernet X-card + Ethernet cable included	FXTE02 (Cable: K95DM2080002A-01)	Sierra Wireless (Grand-TEK Technology)
Data cable (RS-232)	HDM15/DB9F/DD/1.5M	GIGA-Concept
USB cable	88732-8700	MOLEX France



14. Reliability Compliance and Recommended Standards

14.1. Reliability Compliance

The FX Series is compliant with the following requirements.

Table 75. Standards Conformity for the FX Series

Abbreviation	Definition
IEC	International Electro technical Commission
ISO	International Organization for Standardization

14.2. Applicable Standards Listing

The table hereafter gives the basic list of standards applicable to the FX Series.

Note: References to any features can be found from these standards.

Table 76. Applicable Standards and Requirements for the FX Series

Document	Current Version	Title
IEC6006826	7.0	Environmental testing - Part 2.6: Test FC: Sinusoidal Vibration.
IEC60068234	73	Basic environmental testing procedures part 2: Test FD: random vibration wide band - general requirements. Cancelled and replaced by IEC60068-2-64. For reference only.
IEC60068264	2.0	Environmental testing - part 2-64: Test FH: vibration, broadband random and guidance.
IEC60068232	2.0	Basic environmental testing procedures - part 2: Test ED: (procedure 1) Withdrawn & replaced by IEC60068-2-31. For reference only.
IEC60068231	2.0	Environmental testing part 2-31: Test EC: rough handling shocks, primarily for equipment-type specimens.
IEC60068229	2.0	Basic environmental testing procedures - part 2: Test EB and guidance: bump. Withdrawn and replaced by IEC60068-2-27. For reference only.
IEC60068227	4.0	Environmental testing - part 2-27: Test EA and guidance: shock.
IEC60068214	6.0	Environmental testing - part 2-14: Test N: change of temperature.
IEC6006822	5.0	Environmental testing - part 2-2: Test B: dry heat.
IEC6006821	6.0	Environmental testing - part 2-1: Test A: cold.
IEC60068230	3.0	Environmental testing - part 2-30: Test DB: damp heat, cyclic (12 h + 12 h cycle).
IEC6006823	69 w/A1	Basic environmental testing procedures part 2: Test CA: damp heat, steady State. Withdrawn and replaced by IEC60068-2-78. For reference only.
IEC60068278	1.0	Environmental testing part 2-78: Test CAB: damp heat, steady state.

Document	Current Version	Title
IEC60068238	2.0	Environmental testing - part 2-38: Test Z/AD: composite temperature/humidity cyclic test.
IEC60068240	1.0 w/A1	Basic environmental testing procedures - part 2: Test Z/AM combined cold/low air pressure tests.
ISO167501	2ND	Road vehicles - environmental conditions and testing for electrical and electronic equipment - part 1: general.
ISO167502	2ND	Road vehicles - environmental conditions and testing for electrical and electronic equipment - part 2: electrical loads.
ISO167503	2ND	Road vehicles - environmental conditions and testing for electrical and electronic equipment - part 3: mechanical loads.
ISO167504	2ND	Road vehicles - environmental conditions and testing for electrical and electronic equipment - part 4: climatic loads.
IEC60529	2.1 w/COR2	Degrees of protection provided by enclosures (IP code).
IEC60068217	4.0	Basic environmental testing procedures - part 2: Test Q: sealing.
IEC60068218	2.0	Environmental testing - part 2-18: Tests - R and guidance: water.
IEC60068270	1.0	Environmental testing - part 2: tests - test XB: abrasion of markings and letterings caused by rubbing of fingers and hands.
IEC60068268	1.0	Environmental testing - part 2: tests - test I: dust and sand.
IEC60068211	3.0	Basic environmental testing procedures, part 2: test KA: salt mist.
IEC60068260	2.0	Environmental testing - part 2: Test KE: flowing mixed gas corrosion test.
IEC60068252	2.0 w/COR	Environmental testing - part 2: Test KB: salt mist, cyclic (sodium chloride solution).

14.3. Environmental Specifications

The FX Series is compliant with the operating classes listed below. The ideal temperature range of the environment for each operating class is also specified.

Table 77. Operating Class Temperature Range

Conditions	Temperature Range
Operating / Class A	-20 °C to +55°C
Operating / Class B*	-30 °C to +75°C
Operating / Class C*	-30 °C to +85°C
Storage*	-40 °C to +85°C

* Refer to the [Footnotes](#) of Table 42 Real Time Clock Specifications for RTC battery related issues.

14.3.1. Function Status Classification

The classes reported below comply with the Annex “ISO Failure Mode Severity Classification”, ISO Standard 7637, and Section 1.

Note: The word “function” used here only concerns the function performed by the FX Series.

Table 78. ISO Failure Mode Severity Classification

Class	Definition
CLASS A	All equipment/system functions are fulfilled normally (100% functional) during and after the constraint. The FX Series shall exhibit normal function during and after environmental exposure. The FX Series performance shall meet the minimum requirements of 3GPP or appropriate wireless standards.
CLASS B	All equipment/system functions are fulfilled normally during application of the constraint; however, one or several of them may be out of the specified tolerances. After application of the constraint, all functions automatically return within standard limits. The memories shall remain in compliance with Class A. The FX Series shall exhibit the possibility at all times to establish a voice, SMS or DATA call. Unless otherwise stated, full performance should return to normal after the external influence has been removed.
CLASS C	No functional requirement will be fulfilled during the application of the constraint; however, full functionality will automatically be returned after the constraint has been removed.

14.3.2. Reliability Prediction Model

The following tables enumerate the different tests performed on the FX Series and their corresponding conditions and results.

14.3.2.1. Life Stress Test

The following tests the FX Series’ product performance.

Table 79. Life Stress Test

Designation	Condition
Performance Test PT3T° & PT 	Standard: N/A
	Special conditions: <ul style="list-style-type: none"> • Temperature: <ul style="list-style-type: none"> ▪ Class A: -20 °C to +55°C ▪ Class B: -30 °C to +75°C • Rate of temperature change: ± 3°C/min • Recovery time: 3 hours
	Operating conditions: Powered
	Duration: 10 days

14.3.2.2. Environmental Resistance Stress Test

The following tests the FX Series' resistance to extreme temperature.

Table 80. Environmental Resistance Stress Test

Designation	Condition
Cold Test COT 	Standard: IEC 680068-2-1, Test Ab
	Special conditions: <ul style="list-style-type: none"> • Temperature: -40°C • Rate of temperature change: $dT/dt \geq \pm 3^\circ\text{C}/\text{min}$ • Recovery time: 3 hours
	Operating conditions: Un-powered
	Duration: 72 hours

14.3.2.3. Corrosive Resistance Stress Test

The following tests the FX Series' resistance to corrosive atmosphere.

Table 81. Corrosive Resistance Stress Test

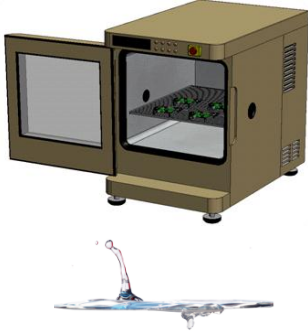
Designation	Condition
Moist Heat Cyclic Test MHCT 	Standard: IEC 60068-2-30, Test Db
	Special conditions: <ul style="list-style-type: none"> • Upper temperature: $+55 \pm 2^\circ\text{C}$ • Lower temperature: $+25 \pm 2^\circ\text{C}$ • RH: <ul style="list-style-type: none"> ▪ Upper temperature: 93% ▪ Lower temperature: 95% • Number of cycles: 21 (1 cycle/24 hours) • Rate of temperature change: $dT/dt \geq \pm 3^\circ\text{C}/\text{min}$ • Recovery time: 3 hours
	Operating conditions: Un-powered
	Duration: 21 days

14.3.2.4. Thermal Resistance Cycle Stress Test

The following tests the FX Series' resistance to extreme temperature cycling.

Table 82. Thermal Resistance Cycle Stress Test

Designation	Condition
Thermal Shock Test TSKT 	Standard: IEC 60068-2-14
	Special conditions: <ul style="list-style-type: none"> • Upper temperature: +90°C • Lower temperature: -40°C • Rate of temperature change: 30s • Number of cycles: 200 • Duration of exposure: 30 minutes • Recovery time: 3 hours
	Operating conditions: Un-powered
	Duration: 72 hours

14.3.2.5. Mechanical Resistance Stress Tests

The following tests the FX Series' resistance to vibrations and mechanical shocks.

Table 83. Mechanical Resistance Stress Tests

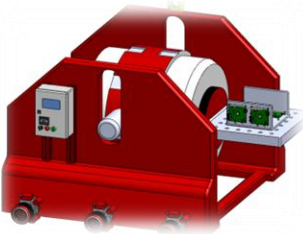
Designation	Condition
Sinusoidal Vibration Test SVT1 	Standard: IEC 60068-2-6, Test Fc
	Special conditions: <ul style="list-style-type: none"> • Frequency range: 10Hz to 1000Hz <ul style="list-style-type: none"> ▪ Displacement: ±5mm (peak) • Frequency range: 16Hz to 62Hz <ul style="list-style-type: none"> ▪ Acceleration: 5G • Frequency range: 62Hz to 200Hz <ul style="list-style-type: none"> ▪ Acceleration: 3G • Frequency range: 200Hz to 1000Hz <ul style="list-style-type: none"> ▪ Acceleration: 1G • Sweep rate: 1 oct/min. • Test duration: 20 cycles • Sweep directions: X, Y and Z
	Operating conditions: Un-powered
	Duration: 72 hours

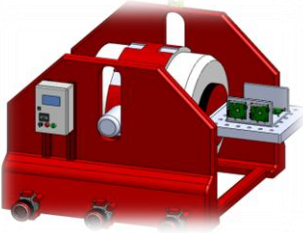
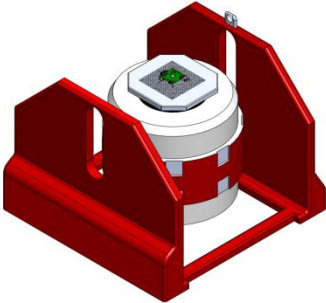
Designation	Condition
<p>Random Vibration Test RVT</p> 	<p>Standard: IEC 60068-2-64</p> <p>Special conditions:</p> <ul style="list-style-type: none"> • Density spectrum: $0.96m^2/s^3$ • Frequency range: <ul style="list-style-type: none"> ▪ $0.1 g^2/Hz$ at 10Hz ▪ $0.01 g^2/Hz$ at 250Hz ▪ $0.0005 g^2/Hz$ at 1000Hz ▪ $0.0005 g^2/Hz$ at 2000Hz • Slope: -3dB/octave • Acceleration: 0.9gRMS • Number of axis: 3 <p>Operating conditions: Un-powered</p> <p>Duration: 16 hours</p>
<p>Mechanical Shock Test MST</p> 	<p>Standard: IEC 60068-2-27, Test Ea</p> <p>Special conditions:</p> <ul style="list-style-type: none"> • Shock Test 1: <ul style="list-style-type: none"> ▪ Wave form: Half sine ▪ Peak acceleration: 30G ▪ Duration: 11ms ▪ Number of shocks: 8 per direction ▪ Number of directions: 6 ($\pm X, \pm Y, \pm Z$) • Shock Test 2: <ul style="list-style-type: none"> ▪ Wave form: Half sine ▪ Peak acceleration: 200G ▪ Duration: 3ms ▪ Number of shocks: 3 per direction ▪ Number of directions: 6 ($\pm X, \pm Y, \pm Z$) • Shock Test 3: <ul style="list-style-type: none"> ▪ Wave form: Half sine ▪ Peak acceleration: 100G ▪ Duration: 6ms ▪ Number of shocks: 3 per direction ▪ Number of directions: 6 ($\pm X, \pm Y, \pm Z$) <p>Operating conditions: Un-powered</p> <p>Duration: 72 hours</p>

14.3.2.6. Handling Resistance Stress Tests

The following tests the FX Series' resistance to handling malfunctions and damage.

Table 84. Handling Resistance Stress Tests

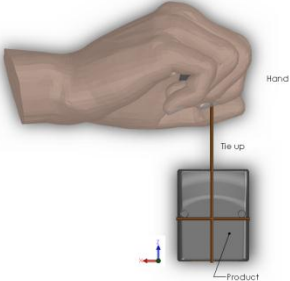
Designation	Condition
ESD Test 	Standard: IEC 1000-4-2 Special conditions: <ul style="list-style-type: none"> • Contact discharges: 10 positive and 10 negative applied • Voltage: ±2kV, ±4kV, ±6kV Operating conditions: Powered Duration: 24 hours
Operational Durability OD	Standard: N/A Special Conditions: <ul style="list-style-type: none"> • SIM Connector: <ul style="list-style-type: none"> ▪ Cycles: 40 ▪ Repetition Rate: 3s per cycle ▪ Objective: Mating and de-mating • System Connector: <ul style="list-style-type: none"> ▪ Cycles: 40 ▪ Repetition Rate: 3s per cycle ▪ Objective: Mating and de-mating • RF Connector: <ul style="list-style-type: none"> ▪ Cycles: 20 ▪ Repetition Rate: 5s per cycle ▪ Objective: Mating and de-mating Operating conditions: Un-powered Duration: 24 hours
Free Fall Test FFT 	Standard : IEC 60068-2-32, Test Ed Special conditions: <ul style="list-style-type: none"> • Drop: 2 samples for each direction • Equivalent drop height: 1.5m • Number of directions: 6 (±X, ±Y, ±Z) • Number of drops/face: 2 Operating conditions: Un-powered Duration:24 hours

15. Certification Compliance and Recommended Standards

15.1. Certification Compliance

Refer to the following tables for the requirements compliance of the FX Series.

Table 85. Standards Conformity for FXT009

Domain	Applicable Standard
Safety standard	EN 60950-1 (ed.2006), UL LISTED (see restrictions in section 15.1.1 UL Listed)
Health standard (EMF Exposure Evaluation)	EN 62311 (ed. 2008)
Efficient use of the radio frequency spectrum	EN 301 511 (V 9.0.2)
EMC	EN 301 489-1 (v1.8.1) EN 301 489-7 (v1.3.1) EN 301 489-24 (v1.4.1)
FCC	FCC Part 15 FCC Part 22, 24
IC	RSS-132 Issue 2 RSS-133 Issue 5
International Standard for Battery	IEC 61951-2

Table 86. Standards Conformity for FX100

Domain	Applicable Standard
Safety & Health	IEC 60950:2005+A1:2009 EN 60950:2006+A11:2009+A1:2010 EN 62311: 2008
Efficient use of the radio frequency spectrum	EN 301 440-1, v1.6.1 EN 301 440-2 v1.4.1 EN 301 511, v9.0.2 EN 301 908-1, v4.2.1 EN 301 908-2, v5.2.1
EMC	EN 301 489-1, v1.9.2 EN 301 489-3, v1.4.1 EN 301 489-7, v1.3.1 EN 301 489-24, v1.5.1
FCC	FCC Part 22, 24

15.1.1. UL Listed

The AirLink FXT009 modem is UL Listed for Standard (STD) bundles only. This UL certification is granted with respect to the following recommendations:

- The FXT009 has to be powered by a Limited Power Source (LPS) as defined on UL60950-1 standard.
- The FXT009 cannot be used with an outdoor antenna.

15.2. Applicable Standards Listing

The table hereafter gives the basic list of standards applicable for 2G and 3G (HSPA).

Note: References to any features can be found from these standards.

Table 87. Applicable Standards and Requirements for FXT009

Document	Current Version	Title
GCF	3.7.1	GSM Certification Forum - Certification Criteria
NAPRD.03	2.6.0	Overview of PCS Type certification review board (PTCRB) Mobile Equipment Type Certification and IMEI control
TS 51.010-1	8.3.0	3rd Generation Partnership Project; Technical Specification Group GSM/EDGE Radio Access Network; Digital cellular telecommunications system (Phase 2+); Mobile Station (MS) conformance specification; Part 1: Conformance specification
TS 51.010-2	8.3.0	3rd Generation Partnership Project; Technical Specification Group GSM/EDGE Radio Access Network; Mobile Station (MS) conformance specification; Part 2: Protocol Implementation Conformance Statement (PICS) proforma specification
TS 51.010-4	4.14.1	3rd Generation Partnership Project; Technical Specification Group GSM/EDGE Radio Access Network; Digital cellular telecommunications system (Phase 2+); Mobile Station (MS) conformance specification; Part 4: SIM Application Toolkit Conformance specification
EN 301 511	9.0.2	Global System for Mobile Communications (GSM); Harmonised standard for mobile stations in the GSM 900 and DCS 1800 bands covering essential requirements under article 3.2 of the R&TTE directive (1999/5/EC)
TS 34.121-1	8.5.0	3rd Generation Partnership Project; Technical Specification Group Radio Access Network; User Equipment (UE) conformance specification; Radio transmission and reception (FDD); Part 1: Conformance specification
TS 34.121-2	8.5.0	3rd Generation Partnership Project; Technical Specification Group Radio Access Network User Equipment (UE) conformance specification; Radio transmission and reception (FDD); Part 2: Implementation Conformance Statement (ICS)
TS 34.123-1	8.5.0	3rd Generation Partnership Project; Technical Specification Group Terminals; User Equipment (UE) conformance specification; Part 1: Protocol conformance specification

Table 88. Applicable Standards and Requirements for FX100

Document	Current Version	Title
GCF-CC	3.46.0	GSM Certification Forum - Certification Criteria
NAPRD.03	5.11	Overview of PCS Type certification review board (PTCRB) Mobile Equipment Type Certification and IMEI control
TS 51.010-1	10.1.0	3rd Generation Partnership Project; Technical Specification Group GSM/EDGE Radio Access Network; Digital cellular telecommunications system (Phase 2+); Mobile Station (MS) conformance specification; Part 1: Conformance specification
TS 51.010-2	10.1.0	3rd Generation Partnership Project; Technical Specification Group GSM/EDGE Radio Access Network; Mobile Station (MS) conformance specification; Part 2: Protocol Implementation Conformance Statement (PICS) proforma specification
TS 51.010-4	4.23.0	3rd Generation Partnership Project; Technical Specification Group GSM/EDGE Radio Access Network; Digital cellular telecommunications system (Phase 2+); Mobile Station (MS) conformance specification; Part 4: SIM Application Toolkit Conformance specification
EN 301 511	9.0.2	Global System for Mobile Communications (GSM); Harmonised standard for mobile stations in the GSM 900 and DCS 1800 bands covering essential requirements under article 3.2 of the R&TTE directive (1999/5/EC)
EN 301 908-2	5.2.1	Global System for Mobile Communications (GSM); Harmonised standard for mobile stations in the GSM 900 and DCS 1800 bands covering essential requirements under article 3.2 of the R&TTE directive (1999/5/EC)



16. Safety Recommendations

16.1. General Safety

It is important to follow any special regulations regarding the use of radio equipment due in particular to the possibility of radio frequency (RF) interference. Please follow the safety advice given carefully.

Switch OFF your Intelligent Embedded Module:

- When in an aircraft. The use of cellular telephones in an aircraft may endanger the operation of the aircraft, disrupt the cellular network and is illegal. Failure to observe this instruction may lead to suspension or denial of cellular telephone services to the offender, or legal action or both,
- When at a refueling point,
- When in any area with a potentially explosive atmosphere which could cause an explosion or fire,
- In hospitals and any other place where medical equipment may be in use.

Respect restrictions on the use of radio equipment in:

- Fuel depots,
- Chemical plants,
- Places where blasting operations are in progress,
- Any other area where signalization reminds that the use of cellular telephone is forbidden or dangerous.
- Any other area where you would normally be advised to turn off your vehicle engine.

There may be a hazard associated with the operation of your FX Series close to inadequately protected personal medical devices such as hearing aids and pacemakers. Consult the manufacturers of the medical device to determine if it is adequately protected.

Operation of your FX Series close to other electronic equipment may also cause interference if the equipment is inadequately protected. Observe any warning signs and manufacturers' recommendations.

The FX Series is designed for and intended to be used in "**fixed**" and "**mobile**" applications:

"**Fixed**" means that the device is physically secured at one location and is not able to be easily moved to another location.

"**Mobile**" means that the device is designed to be used in other than fixed locations and generally in such a way that a separation distance of at least 20 cm (8 inches) is normally maintained between the transmitter's antenna and the body of the user or nearby persons.

The FX Series is not designed for and intended to be used in portable applications (within 20 cm or 8 inches of the body of the user) and such uses are strictly prohibited.

16.2. Vehicle Safety

Do not use your FX Series while driving, unless equipped with a correctly installed vehicle kit allowing 'Hands-Free' Operation.

Respect national regulations on the use of cellular telephones in vehicles. Road safety always comes first.

If incorrectly installed in a vehicle, the operation of the FX Series could interfere with the correct functioning of vehicle electronics. To avoid such problems, make sure that the installation has been performed by qualified personnel. Verification of the protection of vehicle electronics should form part of the installation.

The use of an alert device to operate a vehicle's lights or horn on public roads is not permitted.

16.3. Care and Maintenance

Your FX Series is the product of advanced engineering, design and craftsmanship and should be treated with care. The suggestion below will help you to enjoy this product for many years.

Do not expose the FX Series to any extreme environment where the temperature or humidity is high.

Do not use or store the FX Series in dusty or dirty areas. Its moving parts can be damaged.

Do not attempt to disassemble the embedded module. There are no user serviceable parts inside.

Do not expose the FX Series to water, rain or spilt beverages. It is not waterproof.

Do not abuse your FX Series by dropping, knocking, or violently shaking it. Rough handling can damage it.

Do not place the FX Series alongside computer discs, credit or travel cards or other magnetic media. The information contained on discs or cards may be affected by the embedded module.

The use of third party equipment or accessories, not made or authorized by Sierra Wireless may invalidate the warranty of the embedded module.

Do contact an authorized Service Center in the unlikely event of a fault in the embedded module.

16.4. Your Responsibility

This FX Series is under your responsibility. Please treat it with care, respecting all local regulations. It is not a toy. Therefore, keep it in a safe place at all times and out of the reach of children.

Try to remember your Unlock and PIN codes. Become familiar with and use the security features to block unauthorized use and theft.

17. Reference Documents

For more details, several reference documents can be consulted. The Sierra Wireless documents referenced herein are provided in the Sierra Wireless documentation package; however, the general reference documents which are not Sierra Wireless owned are not provided in the documentation package. Visit the Sierra Wireless Developer Zone at <http://developer.sierrawireless.com/> for the latest documentation available.

17.1. Firmware Documentation

- [1] Open AT Application Framework AT Commands Interface Guide
Reference: WM_DEV_OAT_UGD_079 (version 11 or higher)
- [2] AirPrime SL808xT and Q2698 Open AT Framework Commands Interface Guide
Reference: 4112152
- [3] AirPrime Q26Elite Software User Guide and AT Command Manual
Reference: 4111803
- [4] Customer Release Notes for Firmware 7.50 A2
Reference: 4112261

17.2. X-card Documentation

- [5] X-card Product Technical Specification
Reference: WA_DEV_FEX20_PTS_004
- [6] FXTE02 User Guide
Reference: 4112217
- [7] AirLink FX Series Expansion Card Installation Guide
Reference: 4114312

17.3. Firmware Upgrade Documentation

- [8] Firmware Upgrade Procedure
Reference: WM_SW_GEN_UGD_001



18. List of Abbreviations

Abbreviation	Definition
AC	Alternating Current
ACM	Accumulated Call Meter
AMR	Adaptive Multi-Rate
AT	Attention (prefix for Open AT commands)
CLK	Clock
CMOS	Complementary Metal Oxide Semiconductor
CS	Coding Scheme
CTS	Clear To Send
dB	Decibel
dBc	Decibel relative to the Carrier power
dB _i	Decibel relative to an Isotropic radiator
dBm	Decibel relative to one milliwatt
DC	Direct Current
DCD	Data Carrier Detect
DCE	Data Communication Equipment
DCS	Digital Cellular System
DSR	Data Set Ready
DTE	Data Terminal Equipment
DTMF	Dual Tone Multi-Frequency
DTR	Data Terminal Ready
EEPROM	Electrically Erasable Programmable Read-Only Memory
EFR	Enhanced Full Rate
E-GSM	Extended GSM
EMC	Electromagnetic Compatibility
EMI	Electromagnetic Interference
ESD	Electrostatic Discharges
ETSI	European Telecommunications Standards Institute
FIT	Series of connectors (micro-FIT)
FR	Full Rate
FTA	Full Type Approval
GCF	Global Certification Forum
GND	Ground
GPIO	General Purpose Input Output
GPRS	General Packet Radio Service
GSM	Global System for Mobile communications
HR	Half Rate
HSDPA	High Speed Downlink Packet Access
HSPA	High Speed Packet Access
HSUPA	High Speed Uplink Packet Access
I	Input

Abbreviation	Definition
IEC	International Electrotechnical Commission
IES	Internal Expansion Socket
IESM	Internal Expansion Socket Module
IMEI	International Mobile Equipment Identification
I/O	Input / Output
LED	Light Emitting Diode
MAX	Maximum
ME	Mobile Equipment
MIC	Microphone
Micro-Fit	Family of connectors from Molex
MIN	MINimum
MNP	Microcom Networking Protocol
MO	Mobile Originated
MS	Mobile Station
MT	Mobile Terminated
NOM	Nominal
O	Output
Pa	Pascal (for speaker sound pressure measurements)
PBCCH	Packet Broadcast Control Channel
PC	Personal Computer
PCL	Power Control Level
PDP	Packet Data Protocol
PIN	Personal Identity Number
PLMN	Public Land Mobile Network
PUK	Personal Unblocking Key
RF	Radio Frequency
RFI	Radio Frequency Interference
RI	Ring Indicator
RMS	Root Mean Square
RTS	Request To Send
RX	Receive
SIM	Subscriber Identification Module
SMA	Sub-miniature version A RF connector
SMS	Short Message Service
SNR	Signal-to-Noise Ratio
SPL	Sound Pressure Level
SPK	Speaker
SRAM	Static RAM
TCP/IP	Transmission Control Protocol / Internet Protocol
TDMA	Time Division Multiple Access
TU	Typical Urban fading profile
TUHigh	Typical Urban, High speed fading profile
TX	Transmit
TYP	Typical

Abbreviation	Definition
UMTS	Universal Mobile Telecommunications System
VSWR	Voltage Stationary Wave Ratio
X-card	Expansion Card

>> 19. Packaging

19.1. Contents

The different FX Series variants are available in nine different package configurations.

The table below summarizes the list of accessories delivered in each package and shows the designation used in the Sierra Wireless catalog to help you select the proper configuration set.

Table 89. Configuration Availability for the FX Series

Standard Package	Ready to Use Package	Ready to Use Ethernet Package (available with the FXT009 only)
DC Cable USB cable (for FXT009 only) Holding Bridles	DC Cable USB cable Holding Bridles Cellular Antenna Diversity Antenna (for FX100) GPS Antenna (for FX100) Power Supply Data Cable	DC Cable USB cable Holding Bridles Cellular Antenna Power Supply Data Cable FXTE02 Ethernet X-card Ethernet RJ45 dongle

19.2. Accessories Description

This section describes the accessories used with the FX Series.

19.2.1. GSM Antenna

Table 90. GSM Antenna Description

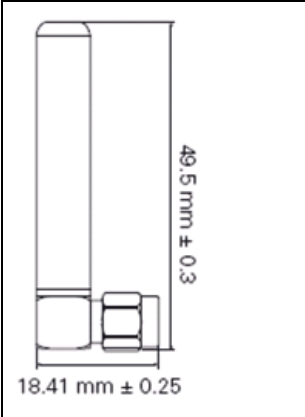
	<ul style="list-style-type: none"> • Antenna Size W x L x H (18.4 x 8.0 x 49.5mm) • Frequency Range supported: 850 / 900 / 1800 / 1900 / 2100 MH • Connector SMA (Male)
---	--

Refer to Table 74 List of Recommended Accessories for more information regarding the recommended accessories.

19.2.2. GPS Antenna

Table 91. GPS Antenna Description

Mechanical	Weight	< 110 grams
	Size	49x39x14mm
	Cable	RG174/U 3meters
	Connector	MMCx m. right angle
	Mounting	Magnetic base
	Housing	Black
Dielectric Antenna	Centre Frequency	1575.42MHz ± 3 MHz
	V.S.W.R	1.5 : 1
	Band Width	±5 MHz
	Impedance	50Ω
	Peak Gain	> 3dBic Based on 7x7cm ground plane
	Gain Coverage	> -4dBic at -90° < 0 < +90°(over 75% Volume)
	Polarization	RHCP
LNA / Filter	LNA Gain (without cable)	28dB (typical)
	Noise Figure	1.5dB
	Filter Out Band Attenuation (f0=1575.42 MHz)	7dB Min f0+/-20MHZ
		20dB Min f0+/-50MHZ
		30dB Min f0+/-100MHZ
	V.S.W.R	< 2.0
	DC Voltage	3.0V to 5.0V
DC Current	10mA Max	

19.2.3. Serial Data Cable

Table 92. Serial Data Cable Description

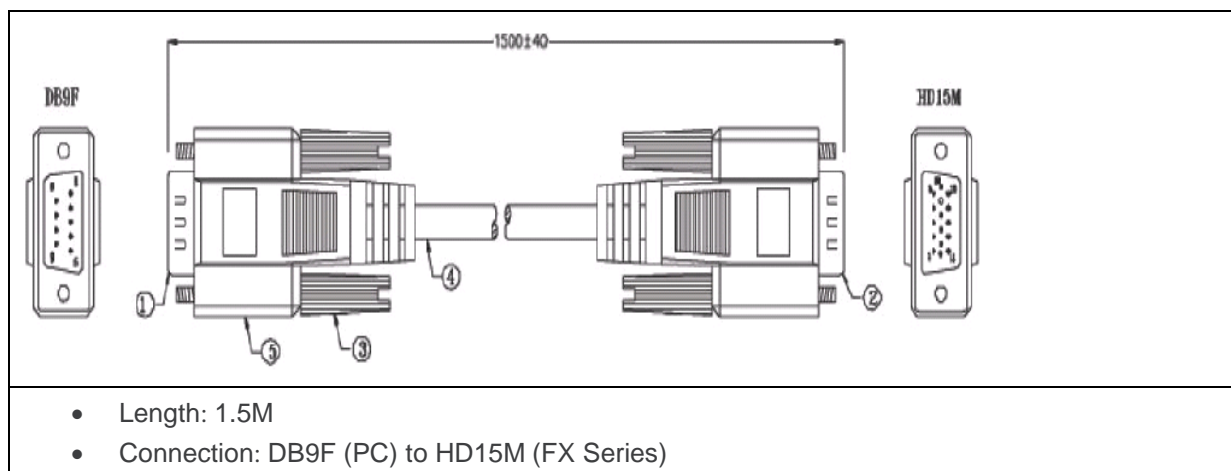

Please refer to section 5.1.2 Serial Interface for more information regarding the pin description.

19.2.4. USB Cable

- Connector to connector USB Type A to Mini-B
- Length 1.5M

19.2.5. 6-wire Cable Accessory used with the FX Series

Table 93. 6-wire Cable Accessory Description

• Length	1.5M
• Connection	10-pin Microfit female connector to 6-wire open ends
• Fuse	2A/250V slow break fuse

Please refer to Table 73 6-Wire Cable Accessory Color Coding for more information regarding the pin description.

19.2.6. Package

Two packaging boxes are available depending on the FX Series bundle.

Table 94. Packaging Description

Standard (STD) Bundle	Ready to Use (RTU) Bundle
Dimensions: 155 x 116 x 77 mm	Dimensions: 221 x 155 x 79 mm

19.2.7. Two Holding Bridles

Please refer to section 8.1 Mounting the FX Series for more information regarding the holding bridles.

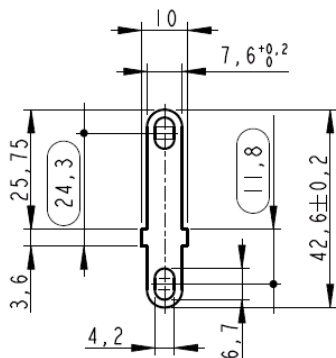

Figure 43. Holding Bridle Description

19.2.8. Power Supply used with the FX Series

Table 95. Power Supply Description

<p>P/N: Q-NA (R) NORTH AMERICA JAPAN</p>	<p>P/N: Q-SAA(R) AUSTRALIA CHINA</p>	<p>P/N: Q-EU(R) EUROPE SOUTH AMERICA</p>
<ul style="list-style-type: none"> • Input Voltage 100-240VAC • Output Voltage 12VDC • Output Current 2.08A, No Minimum Load required • Output Power (Rated) 25W MAX 		

Note that the 240V power supply delivered with Ready to Use bundles has a limited temperature range as listed in the table below.

Table 96. Power Supply Temperature Range for Ready to Use Bundles

Condition	Temperature Range
Operating	0°C to 40°C
Storage	-40 °C to +80°C

20. Product Labeling

A product label is located at the back of the FX Series and provides additional information about the modem.

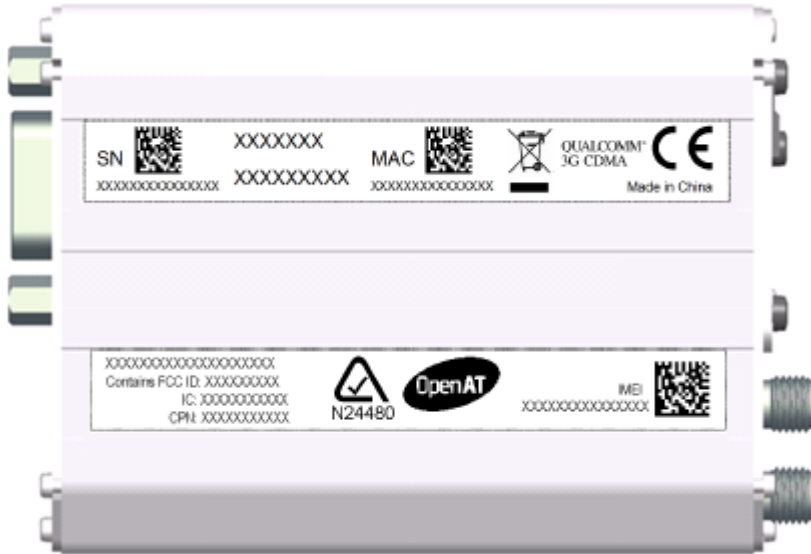

Figure 44. FX Series Product Label

The top label provides the following information:

- Serial number and barcode
- Product Name (FXT009 or FX100)
- Item number
- MAC ID and barcode
- WEEE logo
- Qualcomm CDMA logo (for FX100 variants only)
- CE marking

The bottom label provides the following information:

- Product Name (FXT009 or FX100)
- FCC ID
- IC number
- Customer product number
- A-Tick logo, N24480
- Open AT logo
- IMEI number and barcode

»» | 21. Safety Recommendations (For Information Only)

For the efficient and safe operation of your GSM device, please read the following information carefully.

21.1. RF Safety

21.1.1. General

Your GSM terminal is based on the GSM standard for cellular technology. The GSM standard is spread all over the world. It covers Europe, Asia and some parts of America and Africa. This is the most used telecommunication standard.

Your GSM terminal is actually a low power radio transmitter and receiver. It sends out and receives radio frequency energy. When you use your GSM application, the cellular system which handles your calls controls both the radio frequency and the power level of your cellular modem.

21.1.2. Exposure to RF Energy

There has been some public concern about possible health effects of using GSM terminals. Although research on health effects from RF energy has focused on the current RF technology for many years, scientists have begun research regarding newer radio technologies, such as GSM. After existing research had been reviewed, and after compliance to all applicable safety standards had been tested, it has been concluded that the product was fitted for use.

If you are concerned about exposure to RF energy there are things you can do to minimize exposure. Obviously, limiting the duration of your calls will reduce your exposure to RF energy. In addition, you can reduce RF exposure by operating your cellular terminal efficiently by following the below guidelines.

21.1.3. Efficient Terminal Operation

For your GSM terminal to operate at the lowest power level, consistent with satisfactory call quality:

If your terminal has an extendible antenna, extend it fully. Some models allow you to place a call with the antenna retracted. However your GSM terminal operates more efficiently with the antenna fully extended.

Do not hold the antenna when the terminal is « IN USE ». Holding the antenna affects call quality and may cause the modem to operate at a higher power level than needed.

21.1.4. Antenna Care and Replacement

Do not use the GSM terminal with a damaged antenna. If a damaged antenna comes into contact with the skin, a minor burn may result. Replace a damaged antenna immediately. Consult your manual to see if you may change the antenna yourself. If so, use only a manufacturer-approved antenna. Otherwise, have your antenna repaired by a qualified technician.

Use only the supplied or approved antenna. Unauthorized antennas, modifications or attachments could damage the terminal and may contravene local RF emission regulations or invalidate type approval.

When installing the coaxial cable to the FX Series, it is necessary to ensure that the metal shield is reliably connected to the protective earthing system of the building. The coaxial cable shield shall be connected to the grounded system of the building, as close to the point of cable entry as practical.

21.2. General Safety

21.2.1. Driving

Check the laws and the regulations regarding the use of cellular devices in the area where you have to drive as you always have to comply with them. When using your GSM terminal while driving, please:

- give full attention to driving,
- pull off the road and park before making or answering a call if driving conditions so require.

21.2.2. Electronic Devices

Most electronic equipment, for example in hospitals and motor vehicles is shielded from RF energy. However RF energy may affect some improperly shielded electronic equipment.

21.2.3. Vehicle Electronic Equipment

Check your vehicle manufacturer representative to determine if any on-board electronic equipment is adequately shielded from RF energy.

21.2.4. Medical Electronic Equipment

Consult the manufacturer of any personal medical devices (such as pacemakers, hearing aids, etc...) to determine if they are adequately shielded from external RF energy.

Turn your terminal OFF in health care facilities when any regulations posted in the area instruct you to do so. Hospitals or health care facilities may be using RF monitoring equipment.

21.2.5. Aircraft

Turn your terminal OFF before boarding any aircraft.

- Use it on the ground only with crew permission
- Do not use it in the air

To prevent possible interference with aircraft systems, Federal Aviation Administration (FAA) regulations require you to have permission from a crew member to use your terminal while the aircraft is on the ground. To prevent interference with cellular systems, local RF regulations prohibit using your modem while airborne.

21.2.6. Children

Do not allow children to play with your GSM terminal. It is not a toy. Children could hurt themselves or others (by poking themselves or others in the eye with the antenna, for example). Children could damage the modem, or make calls that increase your modem bills.

21.2.7. Blasting Areas

To avoid interfering with blasting operations, turn your unit OFF when in a « blasting area » or in areas posted : « turn off two-way radio ». Construction crews often use remote control RF devices to set off explosives.

21.2.8. Potentially Explosive Atmospheres

Turn your terminal OFF when in any area with a potentially explosive atmosphere. It is rare, but your modem or its accessories could generate sparks. Sparks in such areas could cause an explosion or fire resulting in bodily injuries or even death.

Areas with a potentially explosive atmosphere are often, but not always, clearly marked. They include fuelling areas such as petrol stations; below decks on boats; fuel or chemical transfer or storage facilities; and areas where the air contains chemicals or particles, such as grain, dust, or metal powders.

Do not transport or store flammable gas, liquid, or explosives, in the compartment of your vehicle which contains your terminal or accessories.

Before using your terminal in a vehicle powered by liquefied petroleum gas (such as propane or butane) ensure that the vehicle complies with the relevant fire and safety regulations of the country in which the vehicle is to be used.



SIERRA
WIRELESS®