



# User Guide

mangOH Development Board



**SIERRA**  
WIRELESS®

4117164

Rev 1

Proprietary and Confidential  
Contents subject to change



---

## Important Notice

Due to the nature of wireless communications, transmission and reception of data can never be guaranteed. Data may be delayed, corrupted (i.e., have errors) or be totally lost. Although significant delays or losses of data are rare when wireless devices such as the Sierra Wireless modem are used in a normal manner with a well-constructed network, the Sierra Wireless modem should not be used in situations where failure to transmit or receive data could result in damage of any kind to the user or any other party, including but not limited to personal injury, death, or loss of property. Sierra Wireless accepts no responsibility for damages of any kind resulting from delays or errors in data transmitted or received using the Sierra Wireless modem, or for failure of the Sierra Wireless modem to transmit or receive such data.

## Safety and Hazards

Do not operate the Sierra Wireless modem in areas where blasting is in progress, where explosive atmospheres may be present, near medical equipment, near life support equipment, or any equipment which may be susceptible to any form of radio interference. In such areas, the Sierra Wireless modem **MUST BE POWERED OFF**. The Sierra Wireless modem can transmit signals that could interfere with this equipment.

Do not operate the Sierra Wireless modem in any aircraft, whether the aircraft is on the ground or in flight. In aircraft, the Sierra Wireless modem **MUST BE POWERED OFF**. When operating, the Sierra Wireless modem can transmit signals that could interfere with various onboard systems.

---

*Note: Some airlines may permit the use of cellular phones while the aircraft is on the ground and the door is open. Sierra Wireless modems may be used at this time.*

---

The driver or operator of any vehicle should not operate the Sierra Wireless modem while in control of a vehicle. Doing so will detract from the driver or operator's control and operation of that vehicle. In some states and provinces, operating such communications devices while in control of a vehicle is an offence.

## Limitation of Liability

The information in this manual is subject to change without notice and does not represent a commitment on the part of Sierra Wireless. SIERRA WIRELESS AND ITS AFFILIATES SPECIFICALLY DISCLAIM LIABILITY FOR ANY AND ALL DIRECT, INDIRECT, SPECIAL, GENERAL, INCIDENTAL, CONSEQUENTIAL, PUNITIVE OR EXEMPLARY DAMAGES INCLUDING, BUT NOT LIMITED TO, LOSS OF PROFITS OR REVENUE OR ANTICIPATED PROFITS OR REVENUE ARISING OUT OF THE USE OR INABILITY TO USE ANY SIERRA WIRELESS PRODUCT, EVEN IF SIERRA WIRELESS AND/OR ITS AFFILIATES HAS BEEN ADVISED OF THE POSSIBILITY OF SUCH DAMAGES OR THEY ARE FORESEEABLE OR FOR CLAIMS BY ANY THIRD PARTY.

Notwithstanding the foregoing, in no event shall Sierra Wireless and/or its affiliates aggregate liability arising under or in connection with the Sierra Wireless product, regardless of the number of events, occurrences, or claims giving rise to liability, be in excess of the price paid by the purchaser for the Sierra Wireless product.

## Patents

This product may contain technology developed by or for Sierra Wireless Inc.

This product includes technology licensed from QUALCOMM®.

This product is manufactured or sold by Sierra Wireless Inc. or its affiliates under one or more patents licensed from InterDigital Group and MMP Portfolio Licensing.

## Copyright

©2015 Sierra Wireless. All rights reserved.

## Trademarks

Sierra Wireless®, AirPrime®, AirVantage®, Skylight™, and the Sierra Wireless and Open AT logos are registered trademarks of Sierra Wireless, Inc. or one of its subsidiaries.

Windows® is a registered trademark of Microsoft Corporation.

QUALCOMM® is a registered trademark of QUALCOMM Incorporated. Used under license.

Other trademarks are the property of their respective owners.

## Contact Information

Sales Desk:	Phone:	1-604-232-1488
	Hours:	8:00 AM to 5:00 PM Pacific Time
	Contact:	<a href="http://www.sierrawireless.com/sales">http://www.sierrawireless.com/sales</a>
Post:	Sierra Wireless 13811 Wireless Way Richmond, BC Canada V6V 3A4	
Technical support:	<a href="mailto:support@sierrawireless.com">support@sierrawireless.com</a>	
RMA support:	<a href="mailto:repairs@sierrawireless.com">repairs@sierrawireless.com</a>	
Fax:	1-604-231-1109	
Web:	<a href="http://www.sierrawireless.com">www.sierrawireless.com</a>	

Consult our website for up-to-date product descriptions, documentation, application notes, firmware upgrades, troubleshooting tips, and press releases:

[www.sierrawireless.com](http://www.sierrawireless.com)

## Revision History

Revision number	Release date	Changes
1	June 2015	Creation (limited release)



# Contents

<b>1. Introduction</b> .....	<b>7</b>
Equipment .....	7
<b>2. Setup and Installation</b> .....	<b>9</b>
Safe Handling Recommendations .....	9
Initial Setup .....	9
<b>3. Hardware Setup and Operation</b> .....	<b>11</b>
Insert/Remove Embedded Modules .....	11
Power Supply .....	14
Select Power Supply .....	14
Connect Battery Backup .....	16
RTC Capacitor .....	16
Insert SIM Card(s) .....	17
Connect Antenna(s) .....	18
Insert/Remove IoT Modules .....	19
Arduino .....	20
Connect Arduino LCD .....	21
Audio Connection .....	21
Ethernet Connection .....	21
USB Host Connection .....	22
RS-232 Console Output Connection .....	22
LED Indicators .....	23
Reset Switches .....	23
Configure Board .....	24
<b>4. Software Setup</b> .....	<b>29</b>
Install / Update Drivers .....	29
Install Terminal Emulator .....	30

Download Firmware Updates . . . . .	30
Write Your First Program . . . . .	30

# >> 1: Introduction

This user guide explains how to set up and begin using Sierra Wireless' mangOH Development Board with the following CF3 form factor modules:

- WP85 Series (Primary)
- WP75 Series (Primary)
- HL 75 Series (Primary/Secondary)
- HL 65 Series (Primary/Secondary)

The mangOH Development Board will also be used for forthcoming CF3 form factor modules.

## Equipment

Table 1-1 details the required and optional components needed to begin using the mangOH Development Board in your development environment.

**Table 1-1: Required/Optional Equipment**



Item	Included in Dev Kit	Details
mangOH Development Board	Yes	The mangOH Development Board supports the modules listed above.
Sierra Wireless CF3 form factor 'Smart' module	Yes	WP8548-G included.
Drivers, Terminal emulation software	No	Driver delivery method TBD
Power supply	No	<ul style="list-style-type: none"> <li>• Output voltage: 5V to 15V</li> <li>• 10 W or higher</li> </ul> <hr/> <p><i>Note: DC power is required to make and establish a full-speed mobile network connection.</i></p> <hr/>

**Table 1-1: Required/Optional Equipment (Continued)**



Item	Included in Dev Kit	Details
USB cable	Yes	USB to Micro-USB cable to communicate with, and provide power for non-transmitting tests, to the board
USB cable	No	USB to Mini-USB cable to connect directly to the Arduino Leonardo board that is incorporated into the mangOH Development Board
SIM/USIM card	No	<p>You need to supply a SIM with an active account, or a test SIM for use with a call box.</p> <hr/> <p><i>Note: Throughout this document, 'SIM' refers to 'SIM' and 'USIM'.</i></p> <hr/>
Antenna	Yes	Main RF antenna
Audio cable (3.5 mm)	No	Audio output cable
Ethernet cable	No	Ethernet cable for use with 100 Mbps Ethernet connector
RS-232 DB9 cable	No	Used for console output
Battery	No	Rechargeable Li-Ion or Li-polymer battery (3V7 nominal) for use when USB/DC power supply is unavailable
Arduino LCD	TBD	

## 2: Setup and Installation

# 2

### Safe Handling Recommendations

**Caution:** Handle the mangOH Development Board carefully to make sure components are not accidentally damaged.

To help prevent accidental damage to the mangOH Development Board:

- Hold the board by the edges (not touching the antenna ports or connectors) to avoid possible ESD damage.

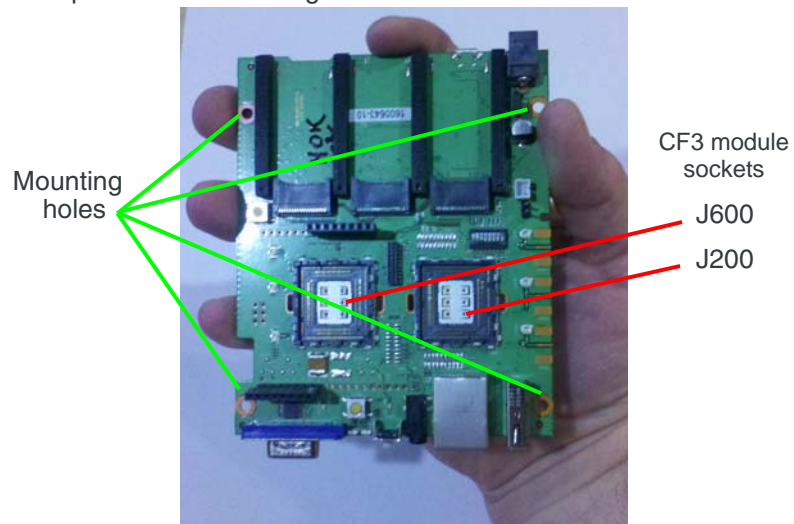

Figure 2-1: Handling the Board

- Avoid touching the CF3 module sockets (J200, J600). The pins in these sockets bend easily.
- Mount the mangOH Development Board in a case, or attach standoffs (not included) to the mounting holes at each corner of the board to avoid damage to components on the bottom side of the board.

### Initial Setup

To begin using the mangOH Development Board, set up your hardware and software:

1. Insert a CF3 form factor module in the primary socket. (See [Insert/Remove Embedded Modules](#) on page 11.)
2. [Select Power Supply](#). See page 14.

3. If you will be establishing a mobile network connection, insert a mini-SIM or micro-SIM and attach the antenna(s). (You can also establish a wired connection using the Ethernet port.):
  - [Insert SIM Card\(s\)](#). See page 17.
  - [Connect Antenna\(s\)](#). See page 18.
4. [Configure Board](#). See page 24.
5. [Install / Update Drivers](#). See page 29.
6. Connect the mangOH Development Board to your computer using the USB cable provided.  
If you selected USB power in [Step 2](#), the power LED lights up.
7. If you selected the DC power supply in [Step 2](#), plug a DC wall adapter into the DC barrel jack. (The wall adapter must meet the requirements in [Table 1-1](#) on page 7.)  
The power LED lights up when power is supplied.
8. [Install Terminal Emulator](#). See page 30.

You are now ready to communicate with the mangOH Development Board. For information on additional hardware features, see [Hardware Setup and Operation](#) on page 11. For instructions on writing a sample first program, see [Write Your First Program](#) on page 30.

## 3: Hardware Setup and Operation

This chapter describes how to install various components on the mangOH Development Board, and how to configure and control features using connectors and switches.

### Insert/Remove Embedded Modules

The mangOH Development Board has two CF3 form factor module sockets for use with Smart and Essential modules.

- Primary (J200)—The primary module can be a 'smart' (WP series) or 'essential' (HL series) module.
- Secondary (J600)—The secondary module, if used, must be an 'essential' module. for example, HL75xx.

To insert a CF3 form factor module:

1. Place the mangOH Development Board Dev Kit face-up (as shown).

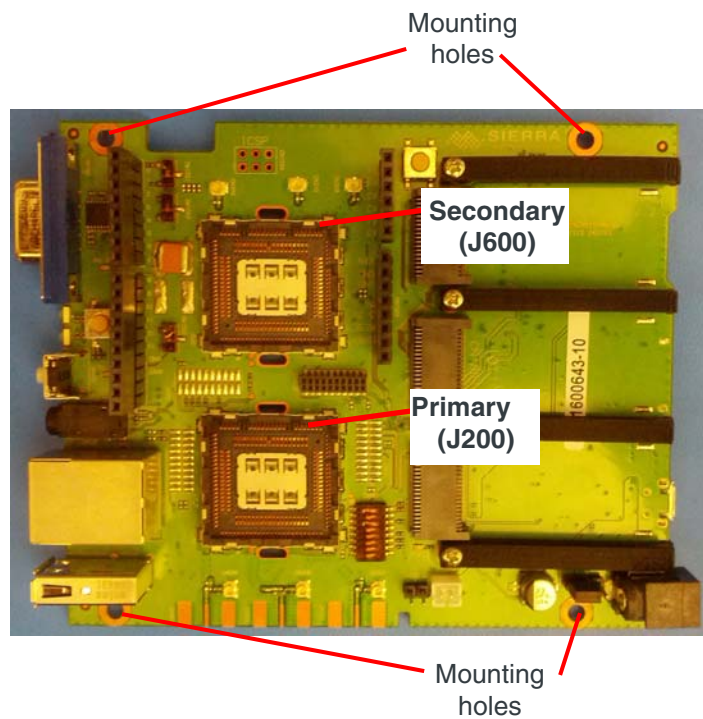

Figure 3-1: mangOH - Top View

2. Hold the module above the socket and line up the polarity marks on the module and socket. (Primary module installation shown.)

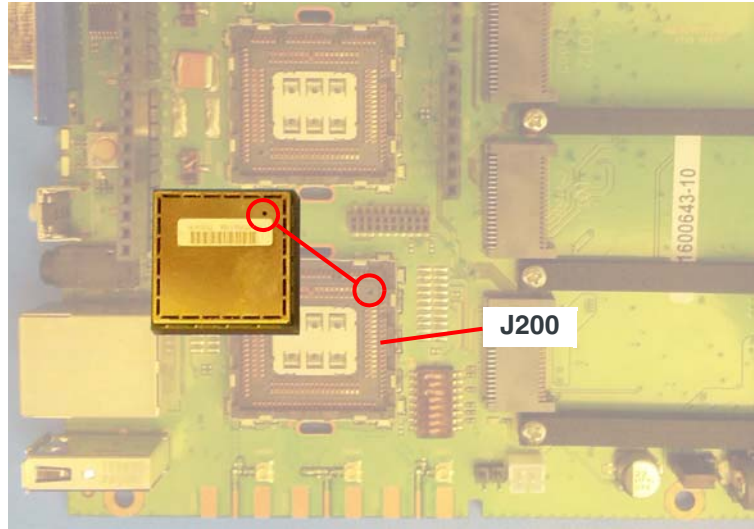

Figure 3-2: CF3 Module Positioning

3. Place the module onto the socket. The module should drop into place when you have it aligned properly. Do not insert at an angle as this may damage the socket pins.

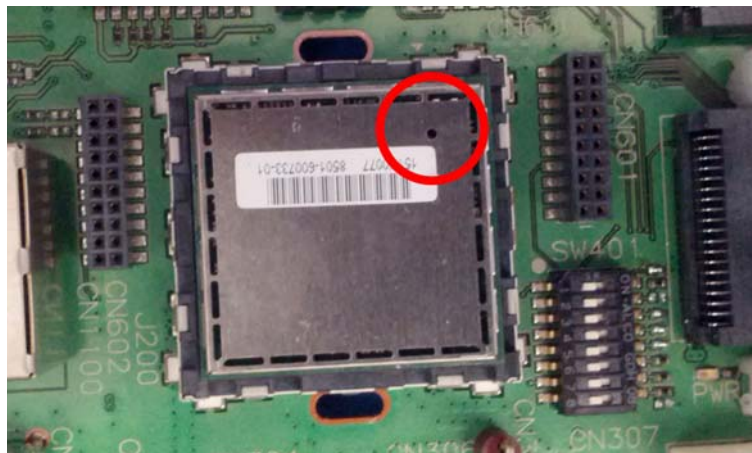

Figure 3-3: CF3 Module Inserted

- 
4. Attach the module cover:
    - a. Hold the module cover at an angle and insert one tab into the corresponding slot on the board (near the center of the board).

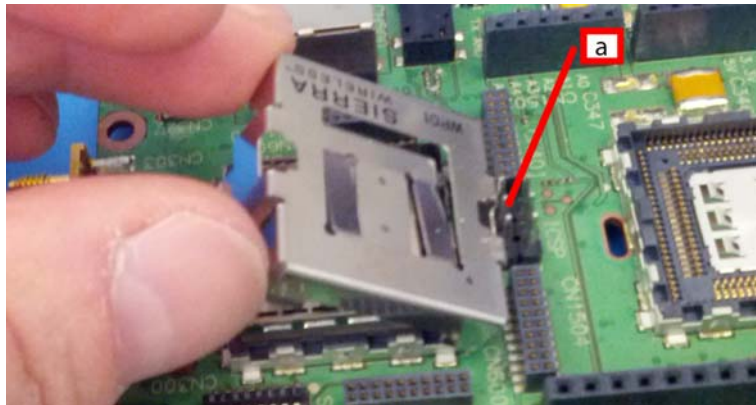

Figure 3-4: Installing Module Cover

- b. Carefully squeeze the other tab and insert it into the corresponding slot.

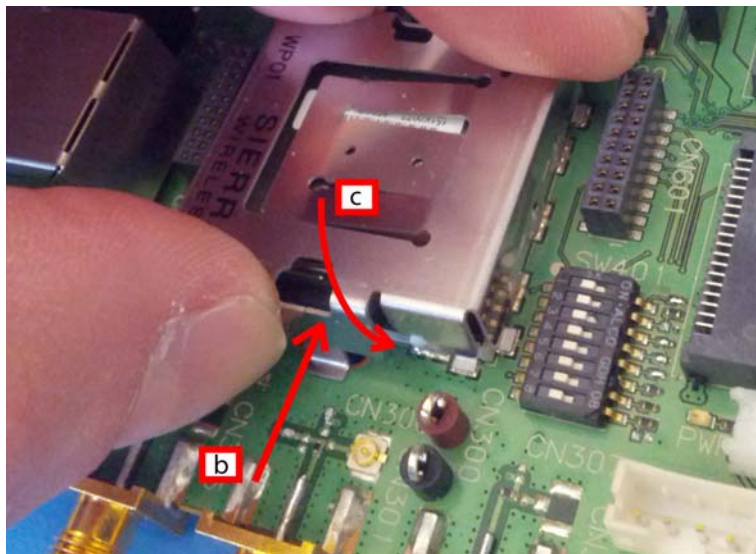

Figure 3-5: Installing Module Cover

- c. Push down gently on the cover so the second tab sits firmly in the slot.

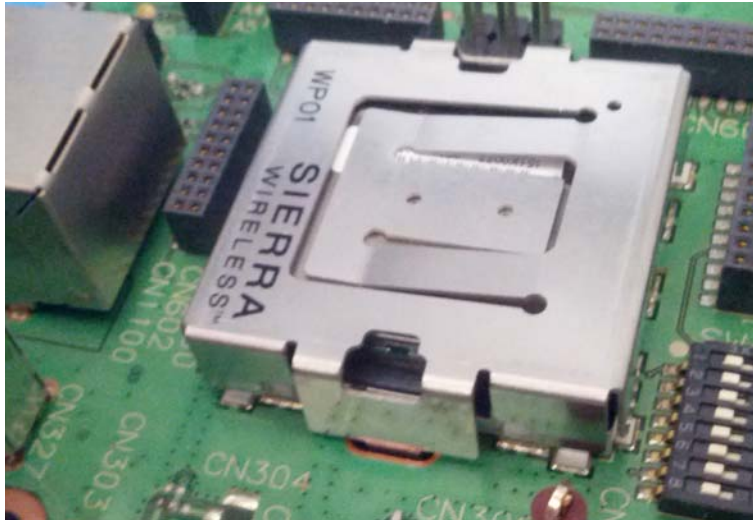

Figure 3-6: Module Cover Installed

To remove a CF3 form factor module (primary module displayed below):

1. Remove the module cover by squeezing both tabs.
2. Carefully pinch the module and pull it straight up out of the socket.

## Power Supply

The mangOH Development Board has three main supplies:

- Primary—USB or DC power
- Secondary—Rechargeable battery
- RTC backup—Backup capacitor for maintaining the RTC

## Select Power Supply

The mangOH Development Board's primary power supply can be a USB connection or a DC wall adapter.

---

*Note: A DC wall adapter must be used if you want to establish and maintain a full-speed mobile network data connection.*

---

To select the power supply:

1. Place the mangOH Development Board face-up and locate the power supply jumper pins (CN1204).

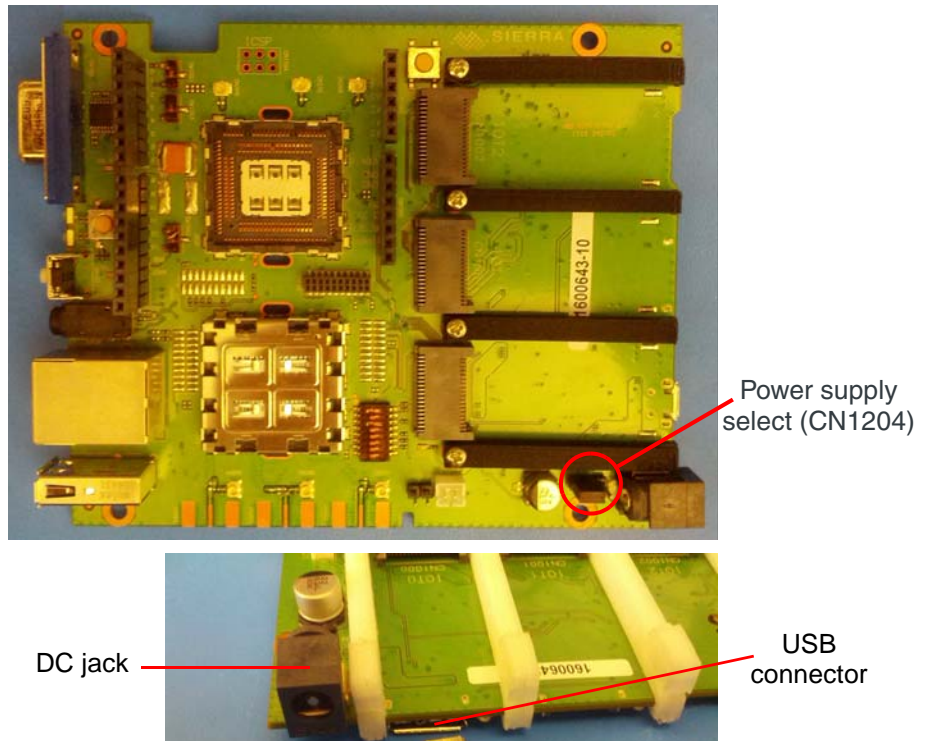

Figure 3-7: mangOH—Power Supply Select (CN1204)

2. Place a jumper across two pins to select the power source:
  - USB power—Place a jumper across the two pins farthest from the DC power jack.
  - DC power—Place a jumper across the pins closest to the DC power jack.

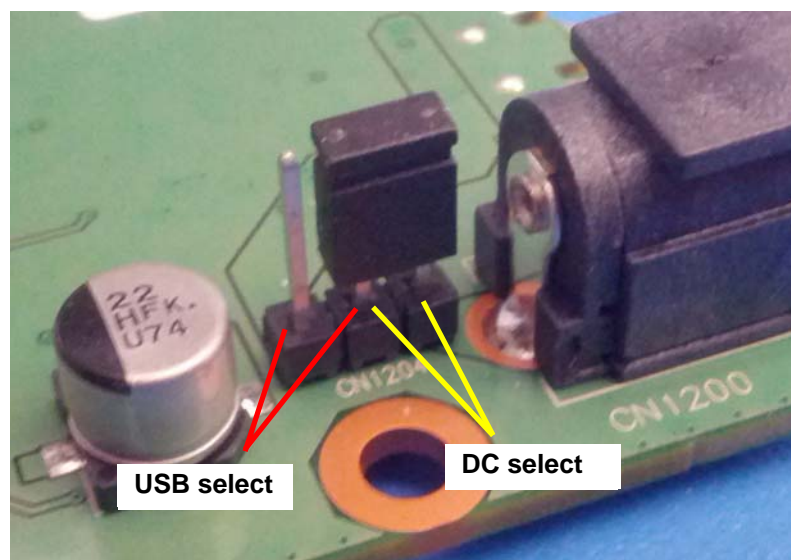
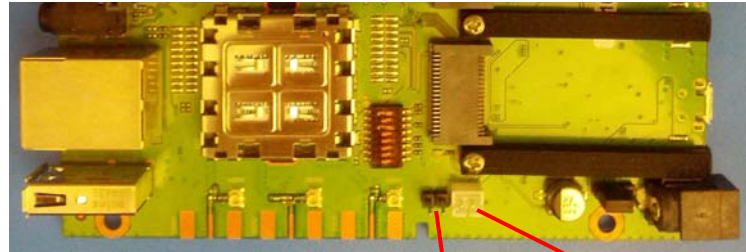

Figure 3-8: Power Source Select (DC power shown)

## Connect Battery Backup

An optional Li-Ion or Li-polymer (3V7 nominal) rechargeable battery can be installed to power the board if the primary power supply fails.



Recharge select  
(CN1203)

Rechargeable battery  
connector (CN1202)

Figure 3-9: mangOH—Battery Backup (CN1202/CN1203)

1. Connect the rechargeable battery to CN1202.
2. If you want the battery to recharge while connected to the board, place a jumper across the pins on CN1203.

---

**Caution:** If a rechargeable battery is not connected to the board, make sure to remove the jumper from CN1203.

---

**Caution:** The board is designed to use a rechargeable Li-Ion or Li-polymer battery. Regular (non-rechargeable) batteries are NOT recommended. However, if a regular battery is used, DO NOT place a jumper on CN1203 as this will cause damage to the battery and possibly the board.

---

## RTC Capacitor

The mangOH Development Board has a capacitor that maintains the RTC.

If required, the capacitor can be discharged by pressing the discharge switch (SW360).

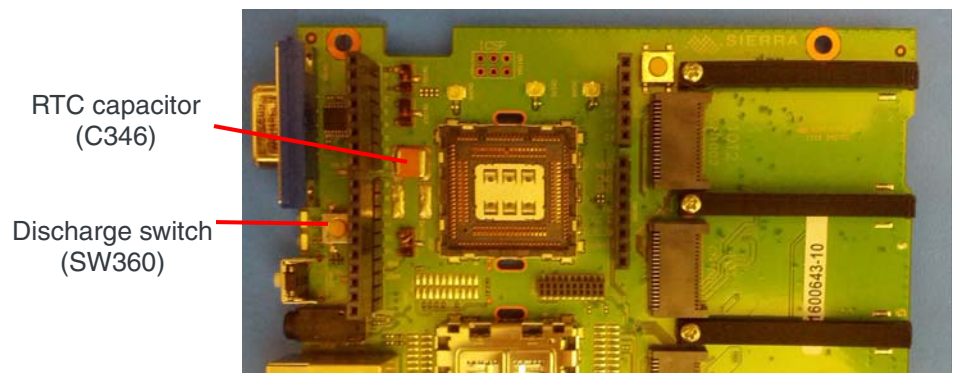

Figure 3-10: mangOH—RTC Capacitor Discharge Switch (SW360)

---

## Insert SIM Card(s)

The mangOH Development Board supports dual SIM functionality (if supported by the CF3 module) through a standard mini-SIM slot (hot-swappable) and a micro-SIM slot (not hot-swappable).

To use a UMTS/LTE module to establish a mobile network connection, you must install one (or two) SIM cards:

- Live card(s) with active accounts, *or*
- Test card(s) for use with a call box (for example, an Agilent 8960 or Rohde & Schwarz CMU200)

---

*Note: A SIM card is not required if you want to connect to a LAN using the Ethernet port.*

---

To install the SIM card(s):

1. Place the Dev Kit face-down (as shown).

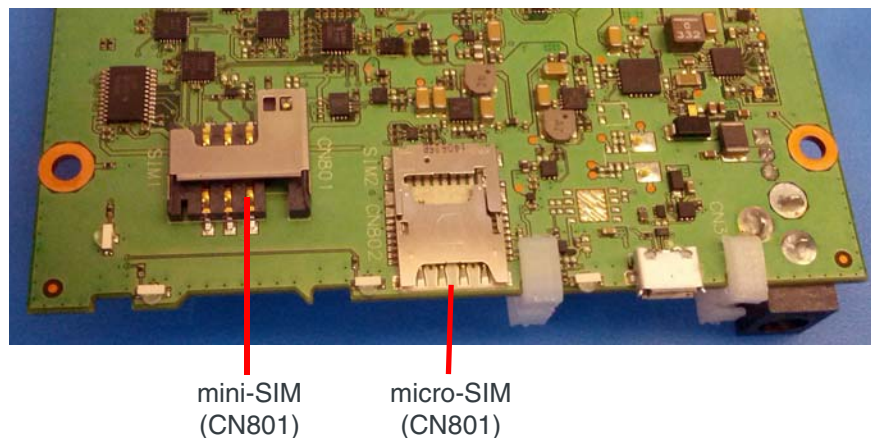

Figure 3-11: mini-SIM Slot (CN801) and micro-SIM Slot Locations

2. Insert the SIM card(s) into the desired slot(s) with circuitry face-down—note the locations of the notched corners of the cards in the following image.

---

*Note: The micro-SIM connector is a dual-connector—the micro-SIM goes in the lower slot (as shown below), and a micro-SD can be placed in the upper slot.*

---

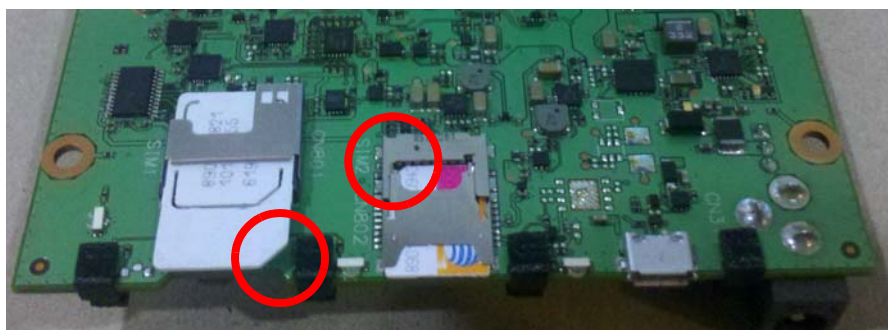

Figure 3-12: SIMs Inserted

## Connect Antenna(s)

The mangOH Development Board includes three antenna ports—Main, Diversity, and GNSS. Depending on the board version, the antenna connectors may be U.FL or SMA connectors.

---

*Note: The Diversity port is used only when the primary module (in J200) supports diversity. The WP85 Series module included with the board does not support diversity.*

---

*Note: If the board has both SMA and U.FL connectors, it is configured by default to use the SMA connectors.*

---

To establish a mobile network connection, you must connect the main antenna, and if desired, a diversity antenna.

To enable GNSS functionality, you must connect a GNSS antenna.

To connect an antenna to the Main, Diversity, or GNSS antenna connector:

1. Place the mangOH Development Board face-up.

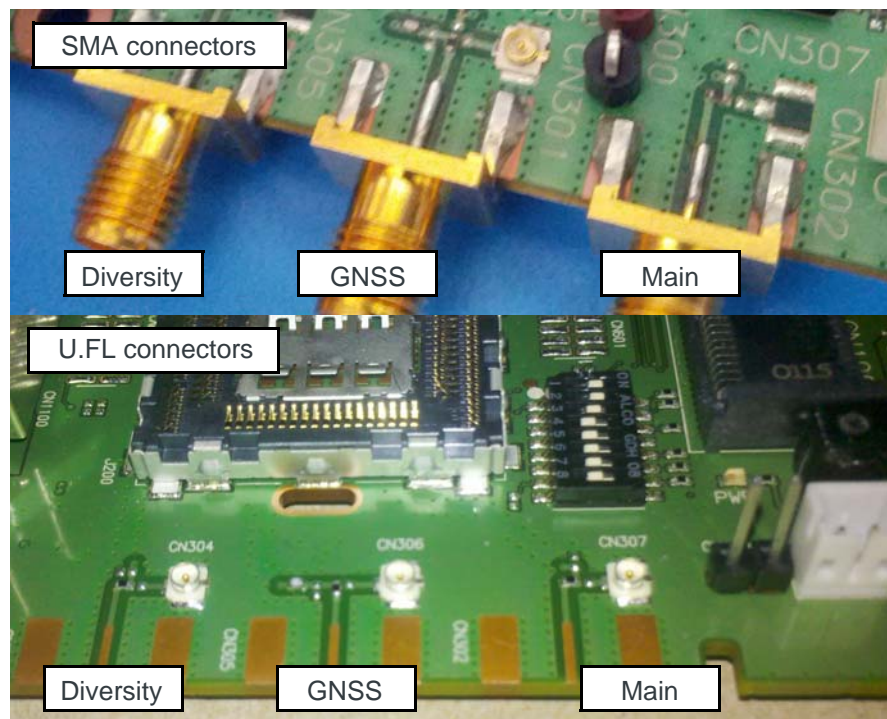

Figure 3-13: Possible Antenna Connector Types

2. Attach the antenna:
  - If the board has only U.FL connectors, position the female connector (on the antenna cable) on the male connector (on the board) and press firmly to get a secure connection.  
(Note that female connectors are rated for a limited number of reconnects before the connector wears out, so should be left connected if possible.)

---

Consider using a U.FL extraction tool to put less strain on the connector during removal.)

- If the board has SMA connectors, screw the antenna onto the desired connector.

## Insert/Remove IoT Modules

The mangOH Development Board includes three IoT module slots.

If the board uses module mounting rails and you want to use a 2-slot or 3-slot IoT module, remove the rail(s) between the slots you will be using.

---

**Caution:** Handle IoT modules carefully to make sure components are not accidentally damaged, and hold modules by their edges to avoid possible ESD damage.

---

To install an IoT module:

1. Check the IoT module to make sure you know which side is the top. (Modules must not be inserted upside-down.)
2. Insert the module parallel to the mangOH Development Board. (Do not try to insert at an angle as this may damage the module or connector.)
  - IoT slot with mounting rails—Slide the IoT module into the rails until it meets the connector, then press firmly to seat the module into the connector.

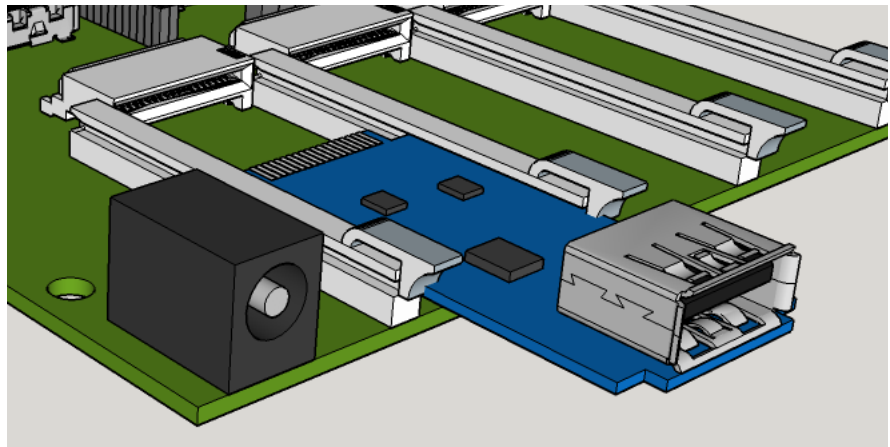

Figure 3-14: Insert IoT Module via Rails

- IoT slot with screw mounts—Position the module so the pins lightly engage the connector, and the other end of the module is supported by the mounts. Press firmly to seat the module into the connector, and secure the module in place using screws provided.

## FOR POSITION ONLY

Figure 3-15: Insert IoT Module via Screw Mounts

To remove an IoT module:

1. If the module is screw mounted, remove the screws.
2. Pull the module straight out, making sure not to touch module components (to prevent physical or ESD damage). Do not pull the module up at an angle as this may damage the module or connector.

## Arduino

The mangOH Development Board incorporates an Arduino Leonardo board.

The Arduino can be controlled via the primary smart module in J200, or directly via a micro-B USB cable connection from your computer.

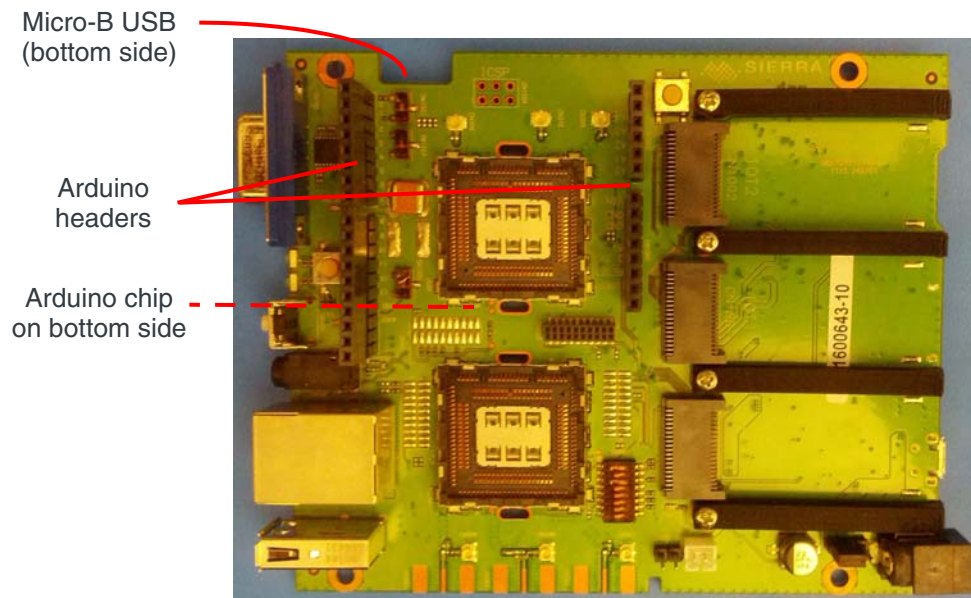

Figure 3-16: mangOH—Arduino

---

## Connect Arduino LCD

To connect the Arduino LCD to the mangOH Development Board:

1. Position the LCD above the Arduino headers. (Note that the two rows of headers have different numbers of pins—make sure to position the LCD correctly.)
2. Hold the LCD by its edges and press straight down into the headers.

## Audio Connection

The mangOH Development Board includes a 3.5 mm audio output jack for use with audio-enabled CF3 modules.

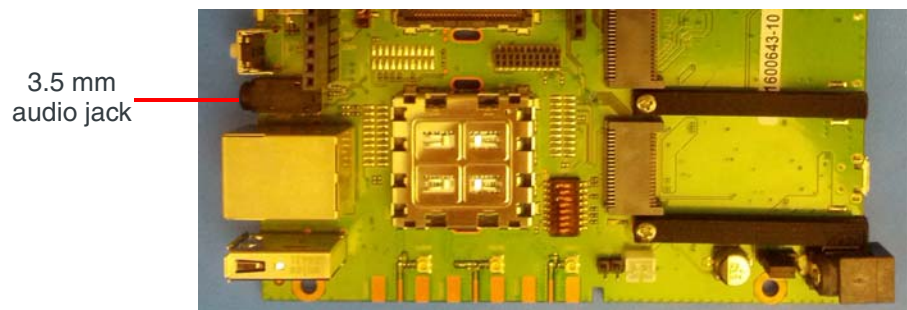

Figure 3-17: mangOH—Audio Output Jack

## Ethernet Connection

The mangOH Development Board includes a 100 Mbps Ethernet port that may be used to connect the board to a LAN.

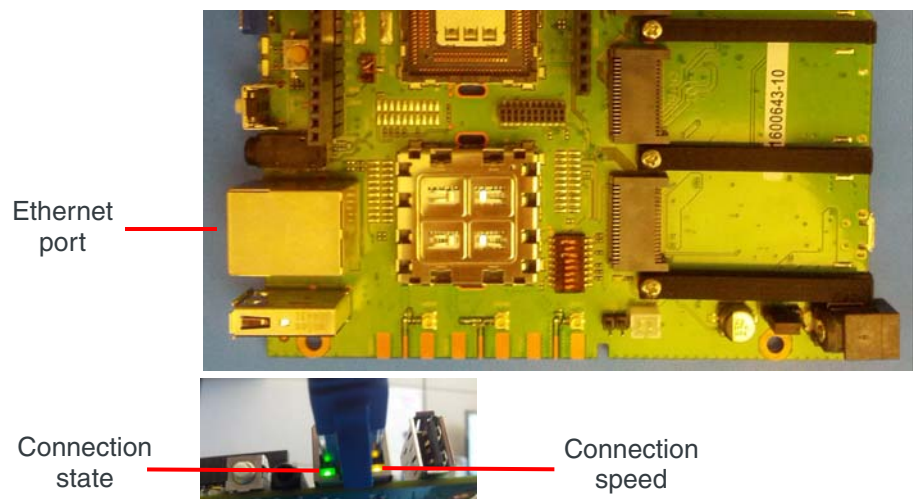
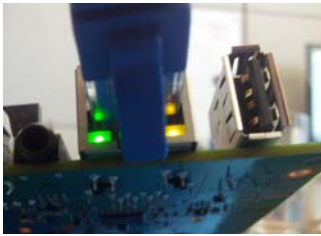

Figure 3-18: mangOH—Ethernet Port

The connector has two LEDs that exhibit the behavior described in the following table.

**Table 3-1: Ethernet LED indicators**



Pattern	Purpose	Description
Green (Left side)	Connection state	<ul style="list-style-type: none"> <li>• Solid—Connected</li> <li>• Blinking—Connected and transmitting/receiving</li> <li>• Off—No connection</li> </ul>
Amber (Right side)	Connection speed	<ul style="list-style-type: none"> <li>• On—100 Mbps</li> <li>• Off—10 Mbps</li> </ul>

## USB Host Connection

The mangOH Development Board includes a USB Host port (USB 2.0) for attaching a peripheral device, memory stick, etc.

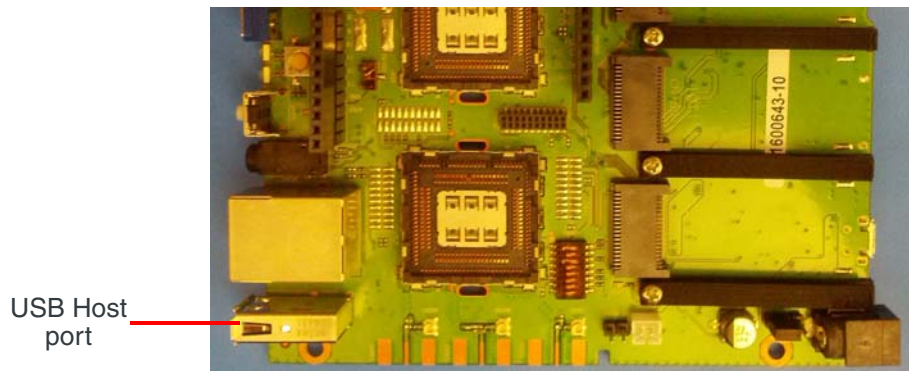

Figure 3-19: mangOH—USB Host Port

## RS-232 Console Output Connection

The mangOH Development Board includes an RS-232 DB9 connector for console output.

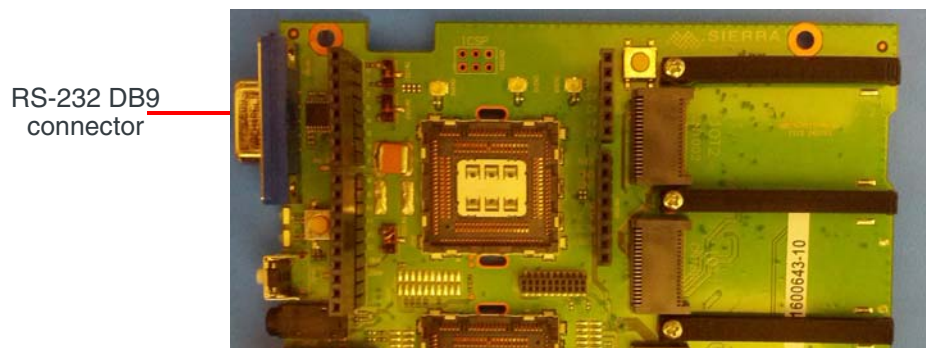

Figure 3-20: mangOH—RS-232 Console Output

---

## LED Indicators

The mangOH Development Board includes the following LED indicators:

- Power—Lights when power is supplied to the board via any power source (USB, DC, battery)
- LED 1— tbd
- LED 2— tbd
- LED 3— tbd
- LED 4— tbd

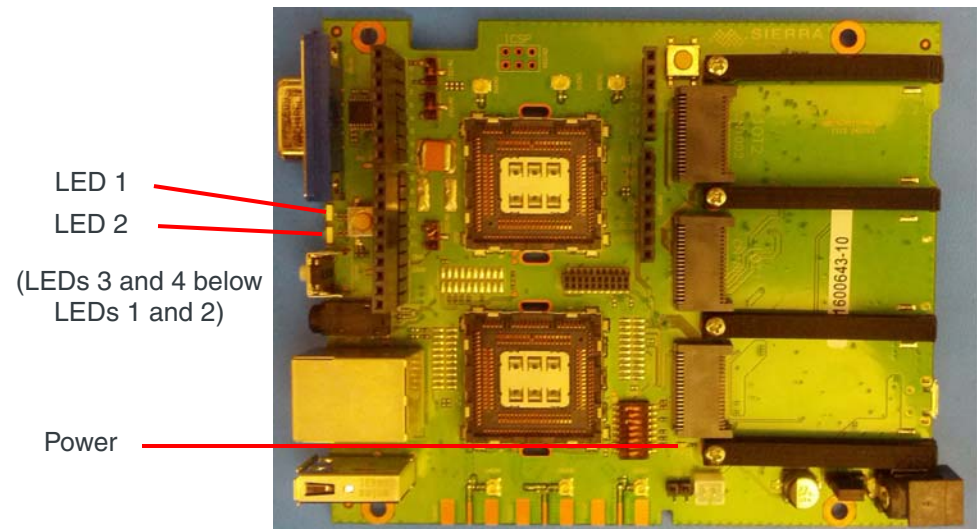

Figure 3-21: mangOH—LED Indicators

## Reset Switches

The mangOH Development Board includes two reset switches:

- Board reset (SW400)—Press and hold for 5 seconds to reset the board (including the Arduino board)
- Arduino reset (SW1500)—Press and hold for 5 seconds to reset the Arduino board.

Arduino reset  
(SW1500)

Board reset  
(SW400)

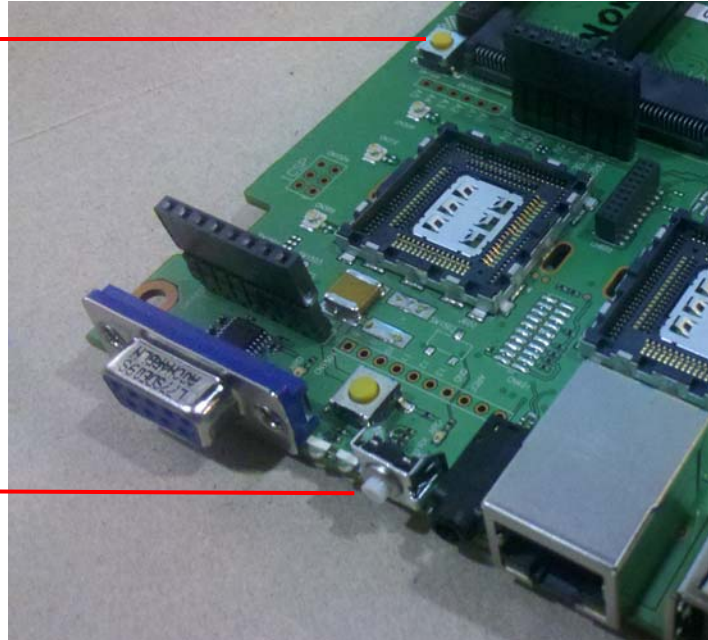

Figure 3-22: mangOH—Reset Switches

## Configure Board

The mangOH Development Board includes several switches and jumpers used to configure the board and module’s operation, as detailed in [Table 3-2](#) on page 24 through [Table 3-9](#) on page 26.

To locate these switches and jumpers, see [Figure 3-23](#) on page 27 and [Figure 3-24](#) on page 28.

**Table 3-2: CN1204—Board Power (+5 V) Select<sup>a</sup>**

Function	Jump 1-2	Jump 2-3
Power supplied by USB cable (through CN311–USB port)	Yes	
Power supplied from Wall cube brick (through CN1200–barrel jack power)		Yes

a. Required: Select one option only (Jump 1-2 or Jump 2-3)

**Table 3-3: CN1203—Battery Recharge Select**

Function	Jump 1-2
Battery will recharge while power is supplied by USB or DC	Yes <sup>a</sup>
Battery will not recharge	No

a. Jumper must not be used if there is no battery connected.

**Table 3-4: SW401—Module Signals Control**

Function	Dip	On/Off	State
<b>POWER_ON</b>	1	On	Enable POWER_ON signal for primary module (J200)
		Off	Disable POWER_ON signal
<b>Reserved</b>	2	On	tbd
		Off	tbd
<b>W_DISABLE_N</b>	3	On	Disable RF power
		Off	Enable RF power
<b>Reserved</b>	4	On	tbd
		Off	tbd
<b>SW_PWR_ON</b>	5	On	Enable POWER_ON signal for secondary module (J600)
		Off	Disable POWER_ON signal
<b>S_TP1_BOOT</b>	6	On	Enable TP1_BOOT functionality for secondary module. Pull the signal low to enter download mode for firmware updates.
		Off	Secondary module functions normally.
<b>TP1_BOOT</b>	7	On	Enable TP1_BOOT functionality for primary module. Pull the signal low to enter download mode for firmware updates.
		Off	Primary module functions normally.
<b>RESET_N</b>	8	On	tbd
		Off	tbd

**Table 3-5: SW1501—Arduino USB Port Assignment**

Function	Position	State
<b>Arduino USB port assignment</b>	1	Arduino USB port connected to Main CF3 socket
	2	Arduino USB port connected to CN330

**Table 3-6: SW1502—Arduino Analog Header (CN1502) Configuration**

Function	Position	State
<b>CN1502 pin assignment</b>	1	CN1502 pins 5 and 6 assigned to SDA, SCL
	2	CN1502 pins 5 and 6 assigned to A4, A5

**Table 3-7: SW1503—Arduino Digital Header (CN1501) Configuration**

Function	Position	State
<b>CN1501 pin assignment</b>	1	CN1503 pins 3,4,5,6 assigned to SS, MOSI, MISO, SCK
	2	CN1503 pins 3,4,5,6 assigned to Io10, Io11, Io12, Io13

**Table 3-8: SW900—SDIO Power control**

Function	Position	State
<b>SDIO voltage</b>	1	SDIO VCC = 3.3V
	2	SDIO VCC = 1.8V

**Table 3-9: SW600—UART selection**

Function	Position	State
<b>UART</b>	1	Primary module's UART bus connects to the secondary module.
	2	Arduino's UART bus connects to the secondary module.

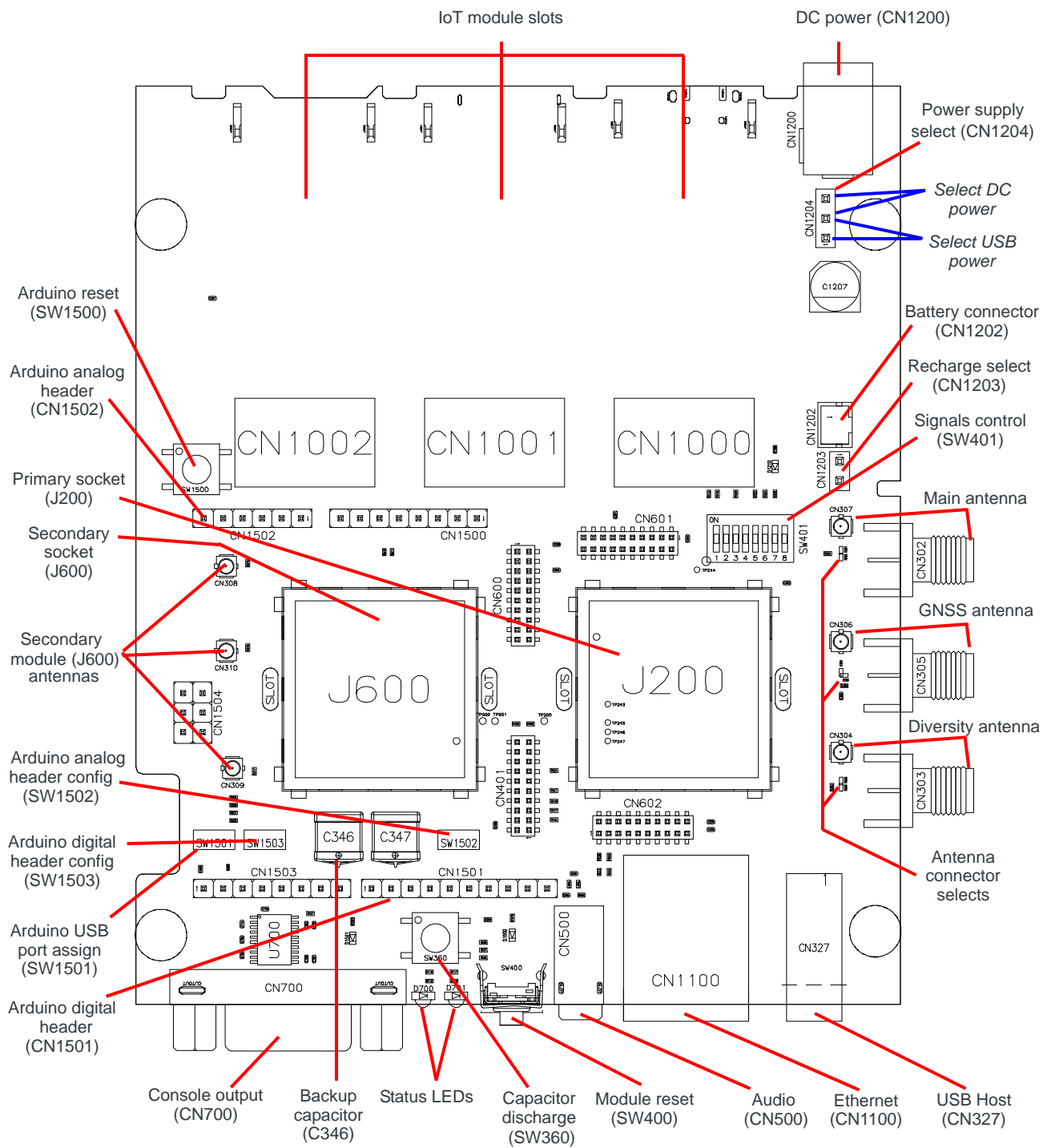

Figure 3-23: mangOH Assembly—Top Side Switches/Connectors

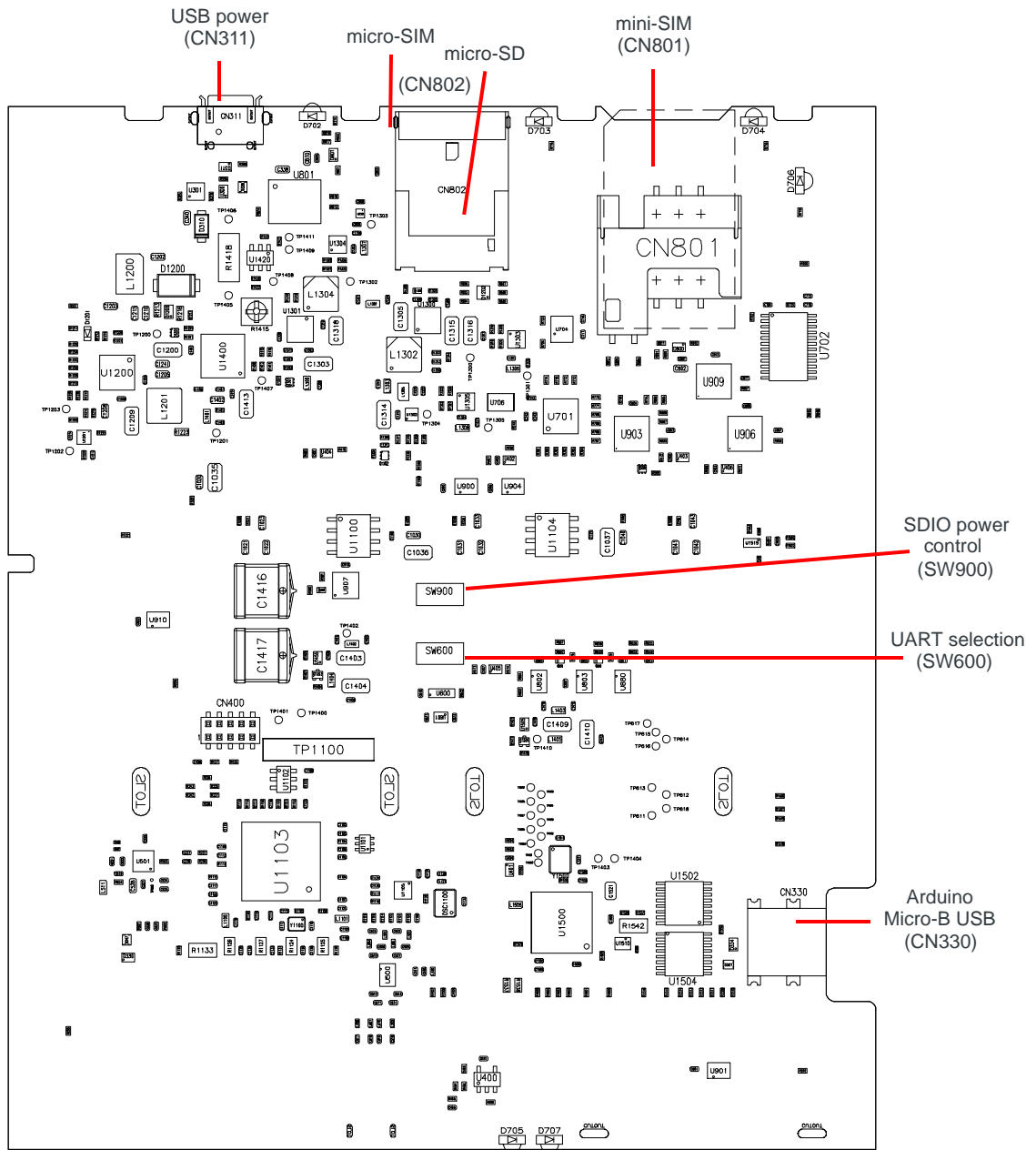

Figure 3-24: mangOH Assembly - Bottom Side Switches/Connectors

## 4: Software Setup

# 4

### Install / Update Drivers

Drivers for the mangOH Development Board and WP8548 module are available in an archive file (GenericDriverPackage.7z) containing a one-click installation file (GenericDriverPackage.exe). The delivery method for this file is TBD.

1. Save the archive file to a local directory.
2. Use an extraction tool (such as 7-Zip or WinZip) to extract the installation file.
3. Run the installation file (GenericDriverPackage.exe). While the drivers install, a progress status message appears above the system tray.
4. When the mangOH Development Board is connected via USB to the computer, display the Device Manager (Control Panel > System > Device Manager).

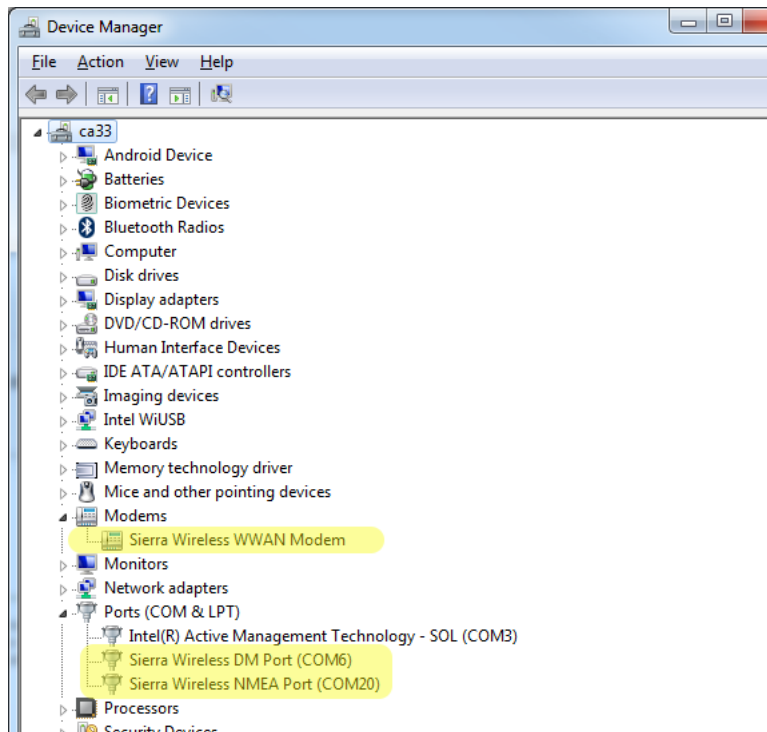

Figure 4-1: Windows Device Manager

If the drivers installed correctly, you will see the following items listed:

- Modems > Sierra Wireless WWAN Modem (This is the module in socket J200.)
- Ports [COM & LPT] > Sierra Wireless DM Port
- Ports [COM & LPT] > Sierra Wireless NMEA Port (This is the port that you will use to communicate with the module from your terminal emulator.)

## Install Terminal Emulator

To communicate with the mangOH Development Board, you must use a terminal emulator program such as Tera Term or HyperTerminal<sup>®</sup> to connect to the board using the Sierra Wireless NMEA Port.

## Download Firmware Updates

Firmware updates will be made available as one-click install executables. The method for obtaining these updates is TBD.

## Write Your First Program

For instructions on building applications, including writing a 'Hello World' program to test your mangOH Development Board, see [www.legato.io/legato-docs/15\\_05/basic\\_apps.html](http://www.legato.io/legato-docs/15_05/basic_apps.html).





**SIERRA**  
WIRELESS®